

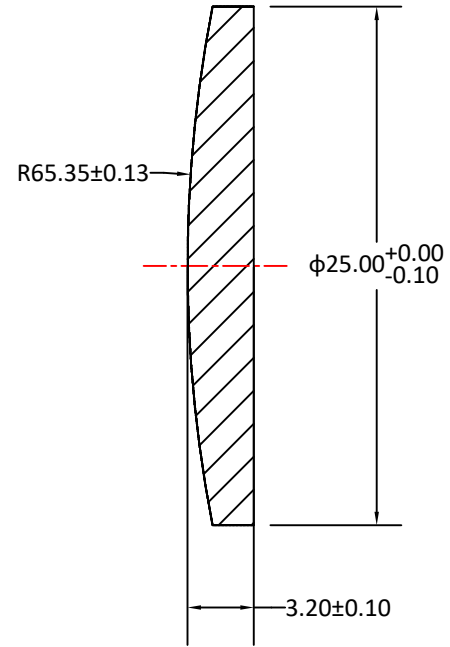

RADIUS	R TOL	POWER	IRRG	CA	DIA	DIA TOL	MATERIAL	INDEX	CT	CT TOL
65.35 CX	±0.13	3	1	90%	25.00	+0/-0.10	H-K9L	517642	3.20	±0.10
Plano	-	3	1	90%						

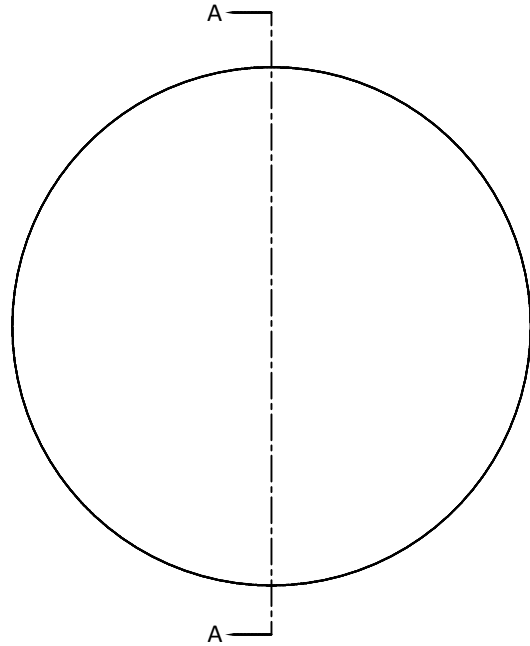

SECTION A-A

Notes:

1. ALL DIMENSIONS IN MM
2. TOLERANCE UNLESS SPECIFIED ± 0.10
3. MATERIAL: OPTICAL GLASS H-K9L
4. MANUFACTURE PER MIL-PRF-13830
5. POLISH TO TESTPLATE WITHIN POWER AND IRREGULARITY INDICATED (FRINGES)
6. FOCAL LENGTH(EFL): 127.00±2%
7. SURFACE QUALITY : 40-20 SCRATCH-DIG
8. CHAMFER EDGES: 0.25×45°MAX UNLESS SPECIFIED
9. CENTRATION TOLERANCE: 2.0' MINUTES MAX
10. COATING: UNCOATED

UNLESS OTHERWISE SPECIFIED:		NAME	DATE				
DIMENSIONS ARE IN mm		DRAWN	Eva Du			7.20.24	
TOLERANCES:		CHECK	Sally Song	7.26.24	TITLE: DIAMETER 25MM, EFL 127.00MM, H-K9L PLANO CONVEX LENSES		
FRACTIONAL ±		ENG APPR.					
ANGULAR: ±3 ARC MIN		MFG APPR.					
TWO PLACE DECIMAL: ±0.10		QA					
THREE PLACE DECIMAL: ±0.05		COMMENTS			SIZE	DWG.NO.	REV
INTERPRET GEOMETRIC TOLERANCING PER:					A	L-PLCX-127_25	0
MATERIAL H-K9L					SCALE:	WEIGHT:	SHEET 1 OF 1
FINISH							
DO NOT SCALE DRAWING		PROJECT NO.					