

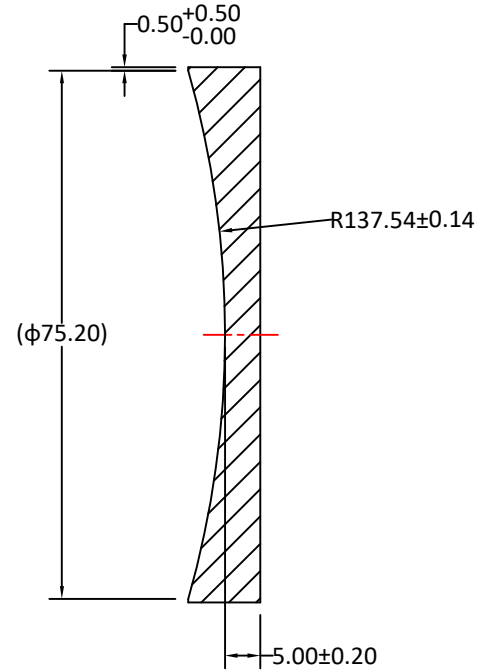

RADIUS	R TOL	POWER	IRRG	CA	DIA	DIA TOL	MATERIAL	INDEX	CT	CT TOL
-137.54 CC	±0.14	3	0.5	90%	76.20	+0/-0.20	JGS1		5.00	±0.20
Plano	-	3	0.5	90%						

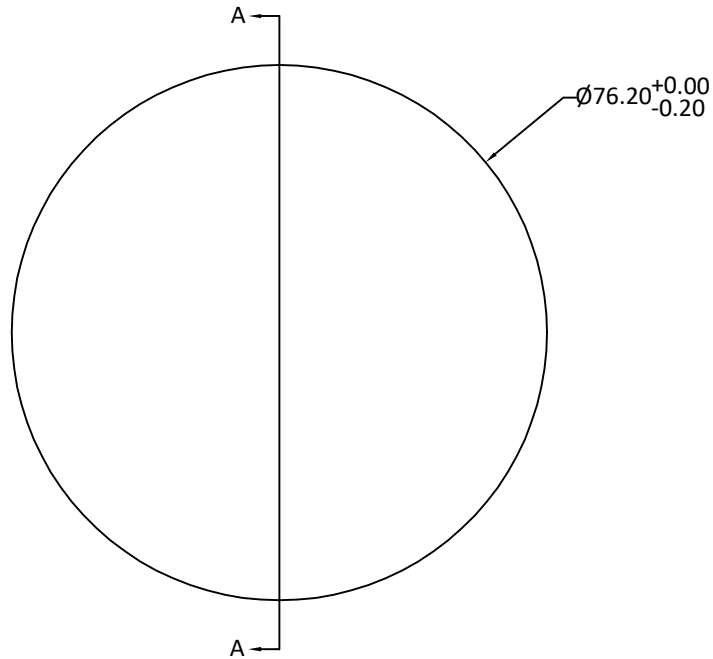

SECTION A-A

Notes:

1. ALL DIMENSIONS IN MM
2. TOLERANCE UNLESS SPECIFIED ± 0.10
3. MATERIAL: GRADE B, FA PER MIL-G-174, FUSED SILICA JGS1, ROHS COMPLIANT
4. MANUFACTURE PER MIL-PRF-13830
5. POLISH TO TESTPLATE WITHIN POWER AND IRREGULARITY INDICATED (FRINGES)
6. FOCAL LENGTH(EFL): -300.00±1%
7. SURFACE QUALITY : 40-20 SCRATCH-DIG
8. CHAMFER EDGES: 0.5×45°MAX UNLESS SPECIFIED
9. CENTRATION TOLERANCE: 1.0' MINUTES MAX
10. COATING: UNCOATED

UNLESS OTHERWISE SPECIFIED:		NAME	DATE	
DIMENSIONS ARE IN mm TOLERANCES: FRACTIONAL ± ANGULAR: ±3 ARC MIN TWO PLACE DECIMAL: ±0.10 THREE PLACE DECIMAL: ±0.05		DRAWN	Sally Song 11.18.24	
INTERPRET GEOMETRIC TOLERANCING PER:		CHECK		TITLE: DIAMETER 76.20MM, EFL -300.00MM, JGS1 PLANO CONCAVE LENSES
MATERIAL H-K9L		ENG APPR.		
FINISH		MFG APPR.		
DO NOT SCALE DRAWING		COMMENTS		SIZE A DWG.NO. L-PC101030076Z REV 0
PROJECT NO.		SCALE:	WEIGHT:	SHEET 1 OF 1