

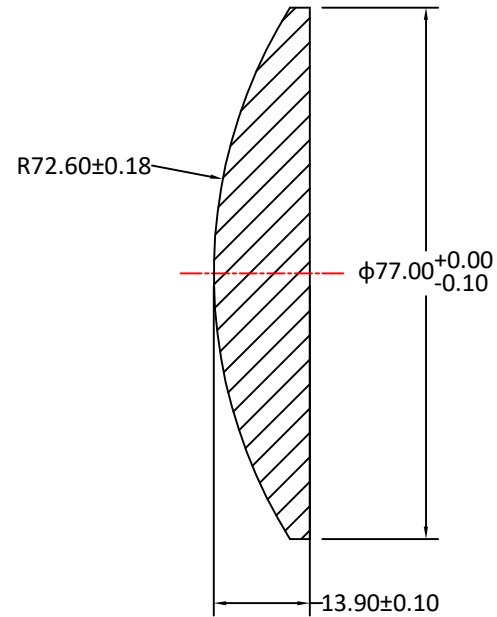

RADIUS	R TOL	POWER	IRRG	CA	DIA	DIA TOL	MATERIAL	INDEX	CT	CT TOL
72.60 CX	±0.18	3	1	90%	77.00	+0/-0.10	H-K9L	517642	13.90	±0.10
Plano	-	3	1	90%						

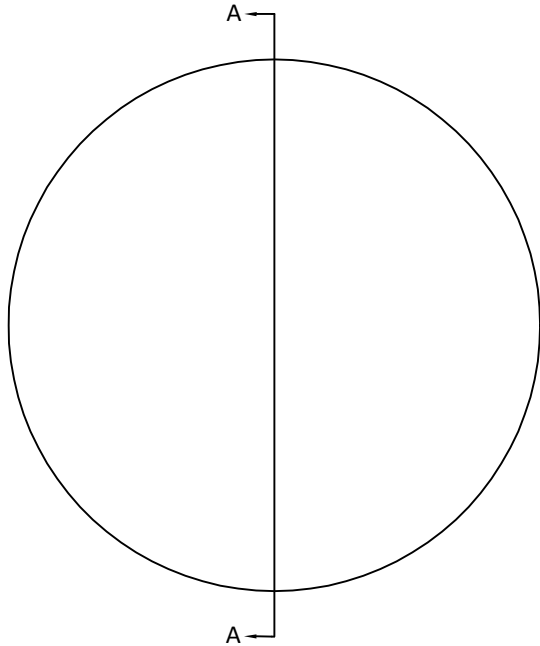

SECTION A-A

Notes:

1. ALL DIMENSIONS IN MM
2. TOLERANCE UNLESS SPECIFIED ± 0.10
3. MATERIAL: GRADE B, FA PER MIL-G-174, CDGM OR EQUIVALENT, ROHS COMPLIANT
4. MANUFACTURE PER MIL-PRF-13830
5. POLISH TO TESTPLATE WITHIN POWER AND IRREGULARITY INDICATED (FRINGES)
6. FOCAL LENGTH(EFL): 140.00±1%
7. SURFACE QUALITY : 40-20 SCRATCH/DIG
8. CHAMFER EDGES: 0.25×45°MAX UNLESS SPECIFIED
9. CENTRATION TOLERANCE: 1.0' MINUTES MAX
10. COATING: UNCOATED

UNLESS OTHERWISE SPECIFIED:		NAME	DATE	
DIMENSIONS ARE IN mm		DRAWN	Eva Du	
TOLERANCES:		CHECK	Sally Song	7.20.24
FRACTIONAL ±		ENG APPR.		
ANGULAR: ±3 ARC MIN		MFG APPR.		
TWO PLACE DECIMAL: ±0.10		QA		
THREE PLACE DECIMAL: ±0.05		COMMENTS		
INTERPRET GEOMETRIC TOLERANCING PER:				
MATERIAL H-K9L		SIZE		DWG.NO.
FINISH		A		L-PX0010140077
DO NOT SCALE DRAWING		PROJECT NO.		REV 0
		SCALE:		WEIGHT:
				SHEET 1 OF 1

TITLE:
DIAMETER 77.00 MM, EFL 140.00MM, H-K9L PLANO CONVEX LENSES