

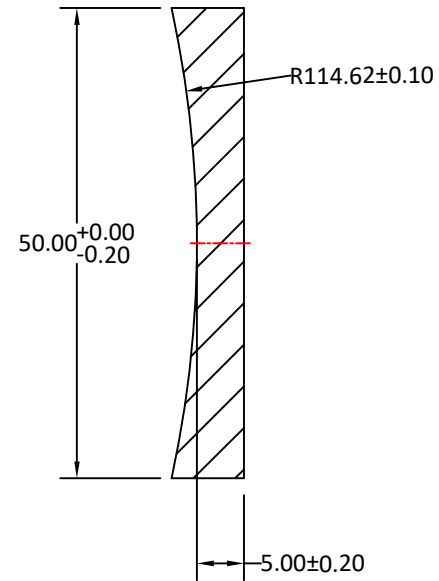

RADIUS	R TOL	POWER	IRRG	CA	DIA	DIA TOL	MATERIAL	INDEX	CT	CT TOL
-114.62 CC	±0.10	3	0.5	90%	50.00	+0/-0.20	JGS1		5.00	±0.20
Plano	-	3	0.5	90%						

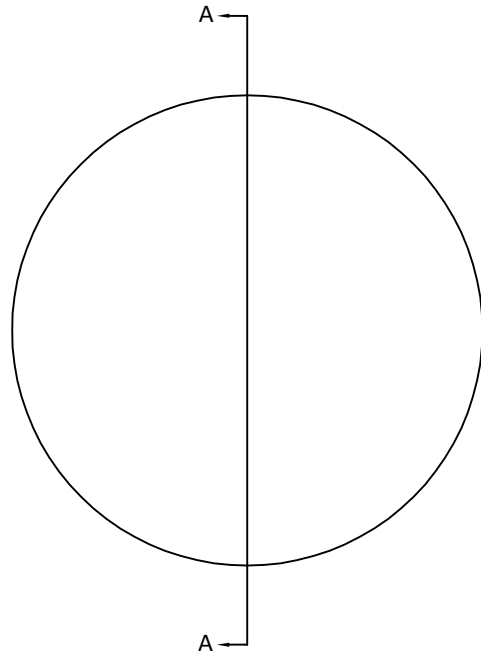

SECTION A-A

Notes:

1. ALL DIMENSIONS IN MM
2. TOLERANCE UNLESS SPECIFIED ± 0.10
3. MATERIAL: GRADE B, FA PER MIL-G-174, FUSED SILICA JGS1, ROHS COMPLIANT
4. MANUFACTURE PER MIL-PRF-13830
5. POLISH TO TESTPLATE WITHIN POWER AND IRREGULARITY INDICATED (FRINGES)
6. FOCAL LENGTH(EFL): -250.00±1%
7. SURFACE QUALITY : 40-20 SCRATCH-DIG
8. CHAMFER EDGES: 0.5×45°MAX UNLESS SPECIFIED
9. CENTRATION TOLERANCE: 1.0' MINUTES MAX
10. COATING: UNCOATED

UNLESS OTHERWISE SPECIFIED:		NAME	DATE		
DIMENSIONS ARE IN mm		DRAWN	Sally Song		
TOLERANCES:		CHECK			TITLE: DIAMETER 50.00MM, EFL -250.00MM, JGS1 PLANO CONCAVE LENSES
FRACTIONAL ±		ENG APPR.			
ANGULAR: ±3 ARC MIN		MFG APPR.			
TWO PLACE DECIMAL: ±0.10		QA			
THREE PLACE DECIMAL: ±0.05		COMMENTS			
INTERPRET GEOMETRIC TOLERANCING PER:					
MATERIAL H-K9L					
FINISH					
DO NOT SCALE DRAWING		PROJECT NO.		SCALE:	
				WEIGHT:	
				SHEET 1 OF 1	
				SIZE <b>A</b>	DWG.NO. <b>L-PC1010250050</b>
					REV <b>0</b>