

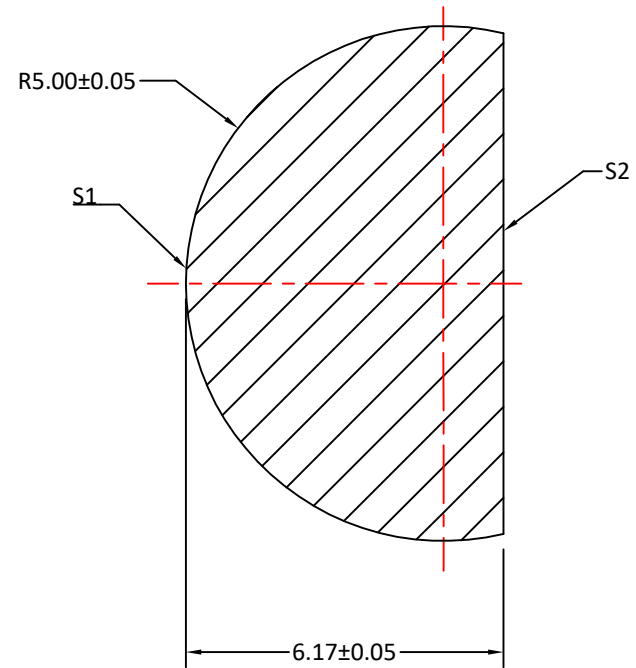

RADIUS	R TOL	POWER	IRRG	CA	DIA	DIA TOL	MATERIAL	INDEX	CT	CT TOL
5.00	±0.05	-	-	-	10.00	+0/-0.10	Silicon		6.17	±0.05
Plano	-	-	-	-						

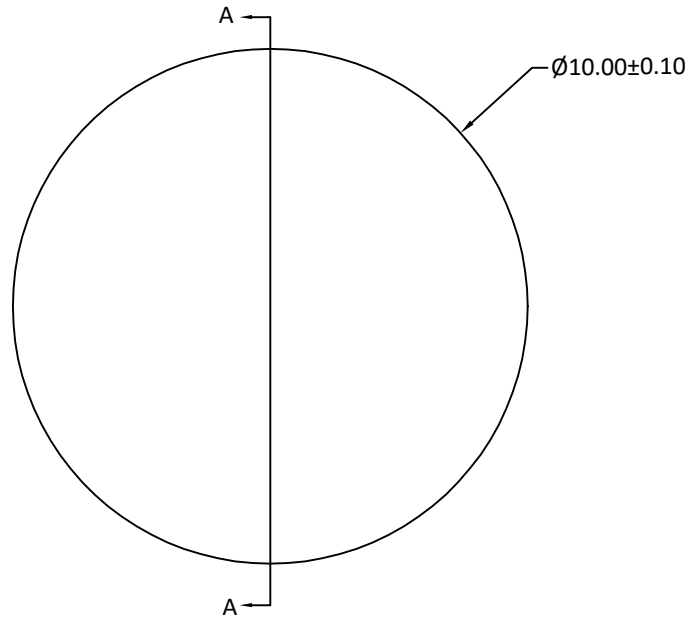

SECTION A-A

Notes:

1. ALL DIMENSIONS IN MM
2. MATERIAL: HRFZ-SILICON, RESISTANCE > 10kΩ*cm
3. S1: HYPER-HEMISPHERICAL, POLISHED
4. S2: FLAT, POLISHED
5. CLEAR APERTURE: ≥90% OF DIAMETER
6. SURFACE QUALITY: 60-40 SCRATCH-DIG
7. THICKNESS TOLERANCE: 0.05mm
8. SURFACE ACCURACY: ±0.01mm DEVIATION FROM IDEAL SPHERE AND PLANE

UNLESS OTHERWISE SPECIFIED:		NAME	DATE	
DIMENSIONS ARE IN mm		DRAWN	Sally Song	
TOLERANCES:		CHECK		
FRACTIONAL ±		ENG APPR.		
ANGULAR: ±3 ARC MIN		MFG APPR.		
TWO PLACE DECIMAL: ±0.10		QA		
THREE PLACE DECIMAL: ±0.05		COMMENTS		
INTERPRET GEOMETRIC TOLERANCING PER:				
MATERIAL SILICON		SIZE		DWG.NO.
FINISH		A		CLZ-Hyper-10-617
DO NOT SCALE DRAWING		PROJECT NO.		REV 0
		SCALE:	WEIGHT:	SHEET 1 OF 1

TITLE:
10.00 DIAMETER, 6.17 THICKNESS TERAHERTZ SILICON
HYPER BALL LENS