

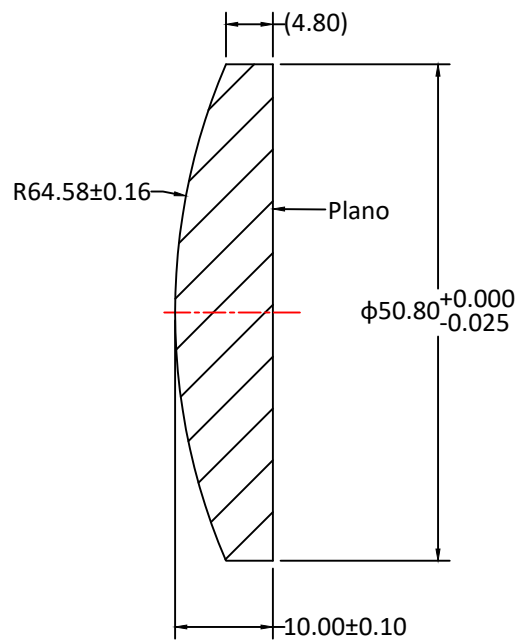

RADIUS	R TOL	POWER	IRRG	CA	DIA	DIA TOL	MATERIAL	INDEX	CT	CT TOL
64.58 CX	±0.16	3	0.5	90%	50.80	+0/-0.025	H-K9L	517642	10.00	±0.10
Plano	-	3	0.5	90%						

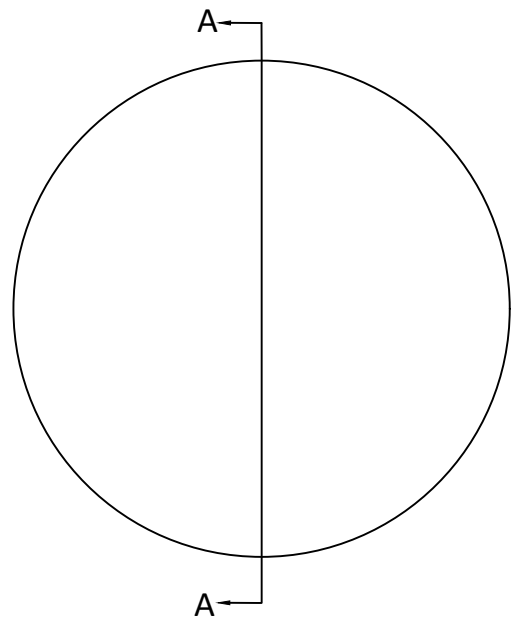

SECTION A-A

Notes:

1. ALL DIMENSIONS IN MM
2. TOLERANCE UNLESS SPECIFIED ± 0.10
3. MATERIAL: OPTICAL GLASS H-K9L
4. MANUFACTURE PER MIL-PRF-13830
5. POLISH TO TESTPLATE WITHIN POWER AND IRREGULARITY INDICATED (FRINGES)
6. FOCAL LENGTH(EFL): 125.00±1%
7. SURFACE QUALITY : 40-20 SCRATCH-DIG
8. CHAMFER EDGES: 0.5×45°MAX UNLESS SPECIFIED
9. CENTRATION TOLERANCE: 1.0' MINUTES MAX
10. COATING: S1 & S2: ¼ WAVE MgF2 @ 550nm R(AVG) < 1.75% FROM 400-700nm H-K9L

UNLESS OTHERWISE SPECIFIED:		NAME	DATE	
DIMENSIONS ARE IN mm TOLERANCES: FRACTIONAL ± ANGULAR: ±3 ARC MIN TWO PLACE DECIMAL: ±0.10 THREE PLACE DECIMAL: ±0.05	DRAWN	Sally Song	9.18.24	
	CHECK			
	ENG APPR.			
	MFG APPR.			TITLE: DIAMETER 50.80MM, EFL 125.00MM, H-K9L, MgF2 COATED, PLANO-CONVEX LENS
INTERPRET GEOMETRIC TOLERANCING PER:	QA	Ann Chen	12.18.24	
MATERIAL H-K9L	COMMENTS			
FINISH				SIZE DWG.NO. REV <b>A</b> L-PX002012550Z <b>0</b>
DO NOT SCALE DRAWING	PROJECT NO.	SCALE:	WEIGHT:	SHEET 1 OF 1