

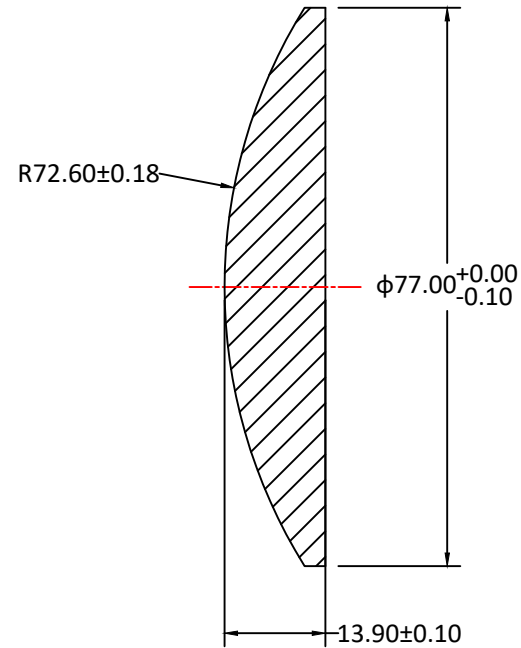

RADIUS	R TOL	POWER	IRRG	CA	DIA	DIA TOL	MATERIAL	INDEX	CT	CT TOL
72.60 CX	±0.18	3	1	90%	77.00	+0/-0.10	H-K9L	517642	13.90	±0.10
Plano	-	3	1	90%						

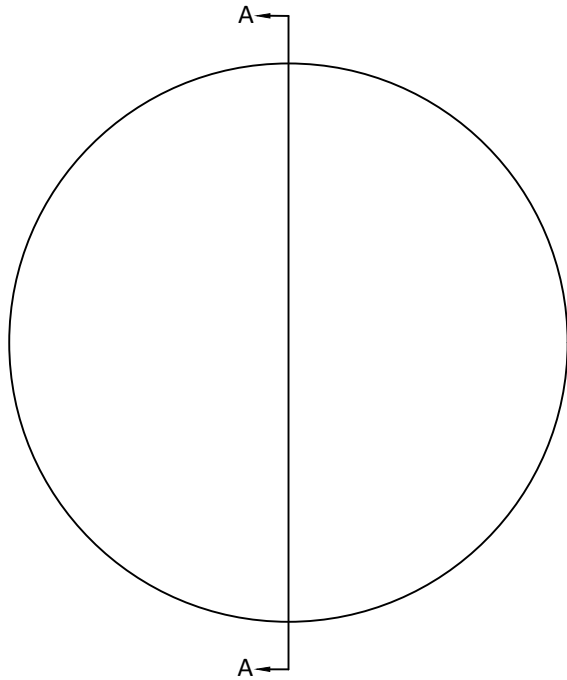

SECTION A-A

Notes:

1. ALL DIMENSIONS IN MM
2. TOLERANCE UNLESS SPECIFIED ± 0.10
3. MATERIAL: GRADE B, FA PER MIL-G-174, CDGM OR EQUIVALENT, ROHS COMPLIANT
4. MANUFACTURE PER MIL-PRF-13830
5. POLISH TO TESTPLATE WITHIN POWER AND IRREGULARITY INDICATED (FRINGES)
6. FOCAL LENGTH(EFL): 140.00±1%
7. SURFACE QUALITY : 40-20 SCRATCH/DIG
8. CHAMFER EDGES: 0.25×45°MAX UNLESS SPECIFIED
9. CENTRATION TOLERANCE: 1.0' MINUTES MAX
10. COATING: S1 & S2:Ravg<0.35% @ 420-680nm @ 0° AOI

UNLESS OTHERWISE SPECIFIED:		NAME	DATE	 <p>TITLE: DIAMETER 77.00 MM, EFL 140.00MM, H-K9L , MgF2 COATED, PLANO-CONVEX LENS</p>
DIMENSIONS ARE IN mm TOLERANCES: FRACTIONAL ± ANGULAR: ±3 ARC MIN TWO PLACE DECIMAL: ±0.10 THREE PLACE DECIMAL: ±0.05	DRAWN	Eva Du	7.15.24	
	CHECK	Sally Song	7.20.24	
	ENG APPR.			
	MFG APPR.			
INTERPRET GEOMETRIC TOLERANCING PER:	QA	Ann Chen	12.17.24	
MATERIAL H-K9L	COMMENTS			
FINISH				
DO NOT SCALE DRAWING	PROJECT NO.	SIZE A	DWG.NO. L-PX0030140077	REV 0
		SCALE:	WEIGHT:	SHEET 1 OF 1