

RADIUS	R TOL	POWER	IRRG	CA
64.58 CX	±0.16	3	0.5	90%
Plano	-	3	0.5	90%

DIA	DIA TOL	MATERIAL	INDEX	CT	CT TOL
50.80	+0/-0.025	H-K9L	517642	10.00	±0.10

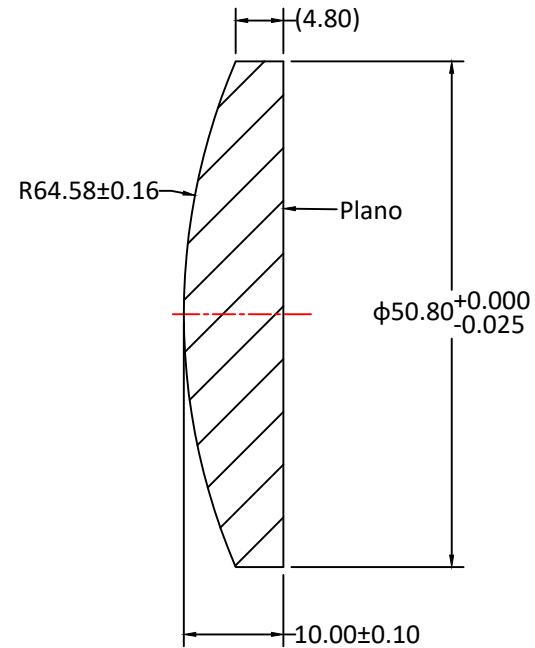
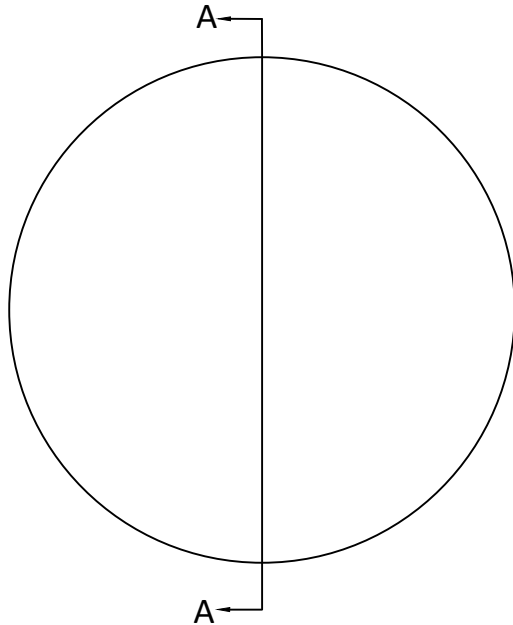

SECTION A-A

Notes:

- ALL DIMENSIONS IN MM
- TOLERANCE UNLESS SPECIFIED ± 0.10
- MATERIAL: OPTICAL GLASS H-K9L
- MANUFACTURE PER MIL-PRF-13830
- POLISH TO TESTPLATE WITHIN POWER AND IRREGULARITY INDICATED (FRINGES)
- FOCAL LENGTH(EFL): 125.00±1%
- SURFACE QUALITY : 40-20 SCRATCH-DIG
- CHAMFER EDGES: 0.5×45°MAX UNLESS SPECIFIED
- CENTRATION TOLERANCE: 1.0' MINUTES MAX
- COATING: S1 & S2: Ravg<0.35% @ 420-680nm @ 0° AOI

UNLESS OTHERWISE SPECIFIED:		NAME	DATE		
DIMENSIONS ARE IN mm		DRAWN	Sally Song		
TOLERANCES:		CHECK			TITLE: DIAMETER 50.80MM, EFL 125.00MM, H-K9L, MgF2 COATED, PLANO-CONVEX LENS
FRACTIONAL ±		ENG APPR.			
ANGULAR: ±3 ARC MIN		MFG APPR.			
TWO PLACE DECIMAL: ±0.10		QA	Ann Chen	12.18.24	SIZE DWG.NO. A L-PX003012550Z
THREE PLACE DECIMAL: ±0.05		COMMENTS			
INTERPRET GEOMETRIC TOLERANCING PER:				REV	0
MATERIAL H-K9L					
FINISH					
DO NOT SCALE DRAWING	PROJECT NO.	SCALE:	WEIGHT:	SHEET 1 OF 1	