

RADIUS	R TOL	POWER	IRRG	CA
51.74 CX	±0.13	3	0.5	90%
Plano	-	3	0.5	90%

DIA	DIA TOL	MATERIAL	INDEX	CT	CT TOL
50.80	+0/-0.025	H-K9L	517642	10.00	±0.10

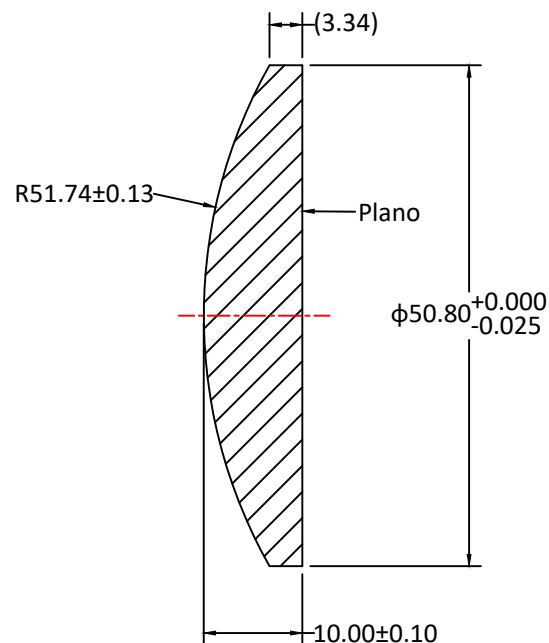
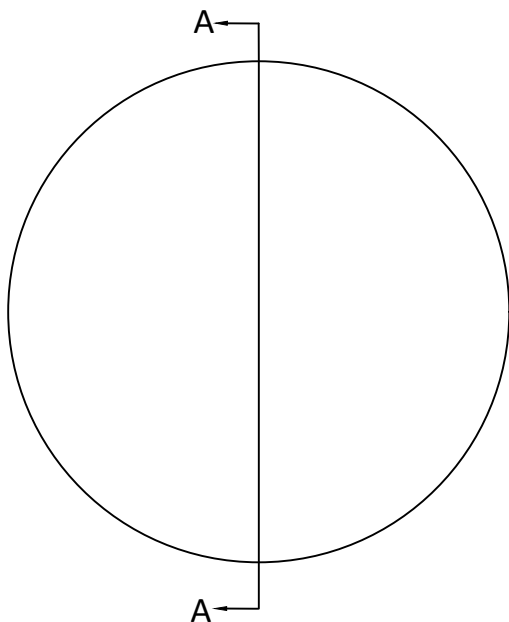

SECTION A-A

Notes:

1. ALL DIMENSIONS IN MM
2. TOLERANCE UNLESS SPECIFIED ± 0.10
3. MATERIAL: OPTICAL GLASS H-K9L
4. MANUFACTURE PER MIL-PRF-13830
5. POLISH TO TESTPLATE WITHIN POWER AND IRREGULARITY INDICATED (FRINGES)
6. FOCAL LENGTH(EFL): 100.00±1%
7. SURFACE QUALITY : 40-20 SCRATCH-DIG
8. CHAMFER EDGES: 0.5×45°MAX UNLESS SPECIFIED
9. CENTRATION TOLERANCE: 1.0' MINUTES MAX
10. COATING: Ravg<0.35% @ 420-680nm @ 0° AOI

UNLESS OTHERWISE SPECIFIED:		NAME	DATE	
DIMENSIONS ARE IN mm		DRAWN	Eva Du	
TOLERANCES:		CHECK	Royan Luo	10.2.24
FRACTIONAL ±		ENG APPR.		
ANGULAR: ±3 ARC MIN		MFG APPR.		
TWO PLACE DECIMAL: ±0.10		QA	Ann Chen	12.18.24
THREE PLACE DECIMAL: ±0.05		COMMENTS		
INTERPRET GEOMETRIC TOLERANCING PER:				
MATERIAL H-K9L		SIZE DWG.NO.		REV
FINISH		A L-PX003010050Z		0
DO NOT SCALE DRAWING		PROJECT NO.	SCALE:	WEIGHT:
				SHEET 1 OF 1

TITLE:  
DIAMETER 50.80MM, EFL 100.00MM, H-K9L, MgF2  
COATED, PLANO-CONVEX LENS