

RADIUS	R TOL	POWER	IRRG	CA	DIA	DIA TOL	MATERIAL	INDEX	CT	CT TOL
51.74 CX	±0.13	3	0.5	90%	50.00	+0/-0.025	H-K9L	517642	10.00	±0.10
Plano	-	3	0.5	90%						

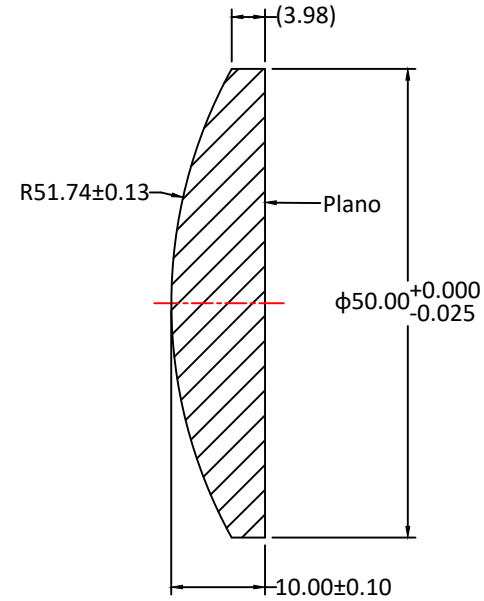
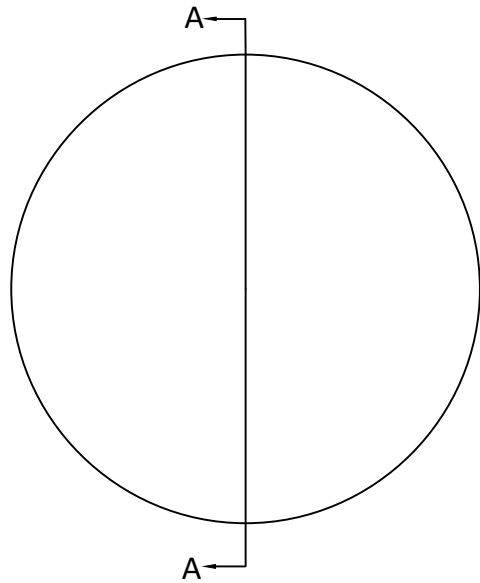

SECTION A-A

Notes:

1. ALL DIMENSIONS IN MM
2. TOLERANCE UNLESS SPECIFIED  $\pm 0.10$
3. MATERIAL: OPTICAL GLASS H-K9L
4. MANUFACTURE PER MIL-PRF-13830
5. POLISH TO TESTPLATE WITHIN POWER AND IRREGULARITY INDICATED (FRINGES)
6. FOCAL LENGTH(EFL):  $100.00 \pm 1\%$
7. SURFACE QUALITY : 40-20 SCRATCH-DIG
8. CHAMFER EDGES:  $0.5 \times 45^\circ$  MAX UNLESS SPECIFIED
9. CENTRATION TOLERANCE:  $1.0'$  MINUTES MAX
10. COATING: S1 & S2:  $R_{avg} < 0.35\%$  @ 420-680nm @  $0^\circ$  AOI

UNLESS OTHERWISE SPECIFIED:		NAME	DATE	CIZ OPTICAL MANUFACTURER FROM CHINA	
DIMENSIONS ARE IN mm TOLERANCES: FRACTIONAL $\pm$ ANGULAR: $\pm 3$ ARC MIN TWO PLACE DECIMAL: $\pm 0.10$ THREE PLACE DECIMAL: $\pm 0.05$	DRAWN	Sally Song	10.2.24	TITLE: DIAMETER 50.00MM, EFL 100.00MM, H-K9L, VIS 0 COATED, PLANO-CONVEX LENS	
	CHECK				
	ENG APPR.				
	MFG APPR.				
INTERPRET GEOMETRIC TOLERANCING PER:	QA	Ann Chen	12.18.24	SIZE DWG.NO. <b>A</b> L-PX0030100050 <b>0</b>	
MATERIAL H-K9L	COMMENTS				
FINISH					
DO NOT SCALE DRAWING	PROJECT NO.	SCALE:	WEIGHT:	SHEET 1 OF 1	