

RADIUS	R TOL	POWER	IRRG	CA	DIA	DIA TOL	MATERIAL	INDEX	CT	CT TOL
51.74 CX	±0.13	3	0.5	90%	50.80	+0/-0.025	H-K9L	517642	10.00	±0.10
Plano	-	3	0.5	90%						

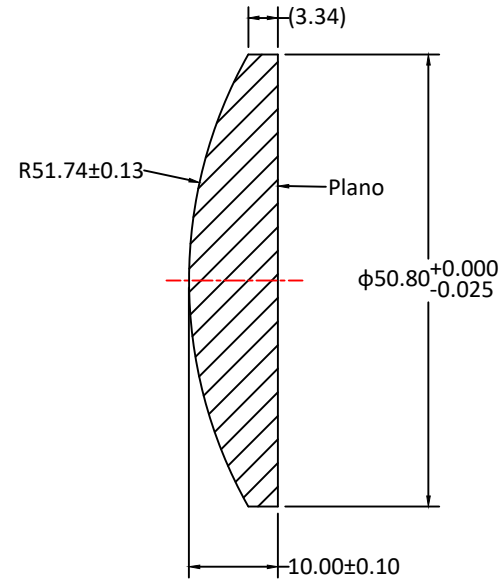
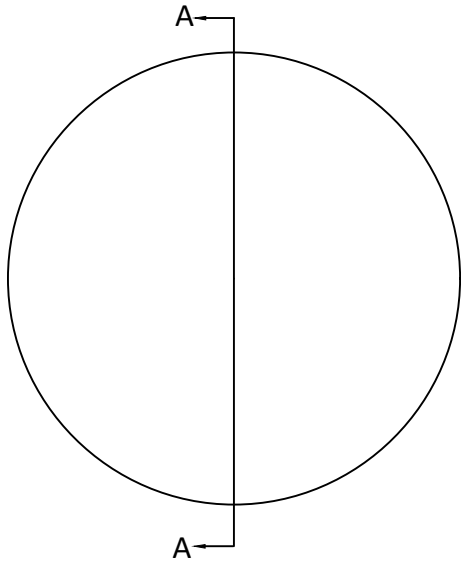

SECTION A-A

Notes:

1. ALL DIMENSIONS IN MM
2. TOLERANCE UNLESS SPECIFIED ± 0.10
3. MATERIAL: OPTICAL GLASS H-K9L
4. MANUFACTURE PER MIL-PRF-13830
5. POLISH TO TESTPLATE WITHIN POWER AND IRREGULARITY INDICATED (FRINGES)
6. FOCAL LENGTH(EFL): 100.00±1%
7. SURFACE QUALITY : 40-20 SCRATCH-DIG
8. CHAMFER EDGES: 0.5×45°MAX UNLESS SPECIFIED
9. CENTRATION TOLERANCE: 1.0' MINUTES MAX
10. COATING: Ravg<0.35% @ 420-680nm @ 0° AOI

UNLESS OTHERWISE SPECIFIED:		NAME	DATE	
DIMENSIONS ARE IN mm TOLERANCES: FRACTIONAL ± ANGULAR: ±3 ARC MIN TWO PLACE DECIMAL: ±0.10 THREE PLACE DECIMAL: ±0.05		DRAWN	Eva Du 9.28.24	
INTERPRET GEOMETRIC TOLERANCING PER:		CHECK	Royan Luo 10.2.24	TITLE: DIAMETER 50.80MM, EFL 100.00MM, H-K9L, VIS 0 COATED, PLANO-CONVEX LENS
MATERIAL H-K9L		ENG APPR.		
FINISH		MFG APPR.		
DO NOT SCALE DRAWING		QA	Ann Chen 12.18.24	SIZE <b>A</b> DWG.NO. <b>L-PX003010050Z</b> REV <b>0</b>
PROJECT NO.		COMMENTS		SCALE: WEIGHT: SHEET 1 OF 1