

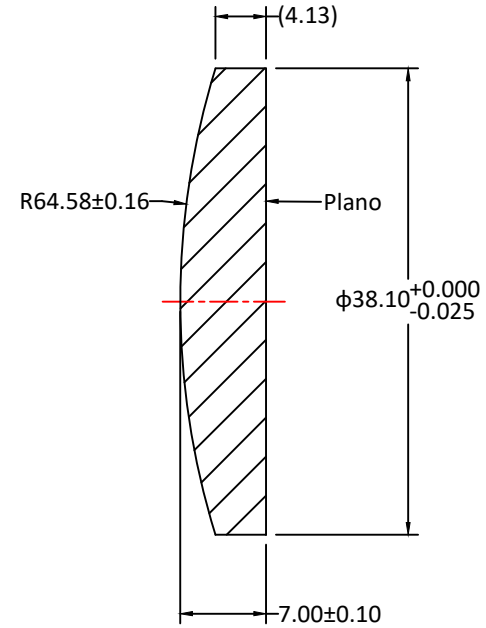

RADIUS	R TOL	POWER	IRRG	CA	DIA	DIA TOL	MATERIAL	INDEX	CT	CT TOL
64.58 CX	±0.16	3	0.5	90%	38.10	+0/-0.025	H-K9L	517642	7.00	±0.10
Plano	-	3	0.5	90%						

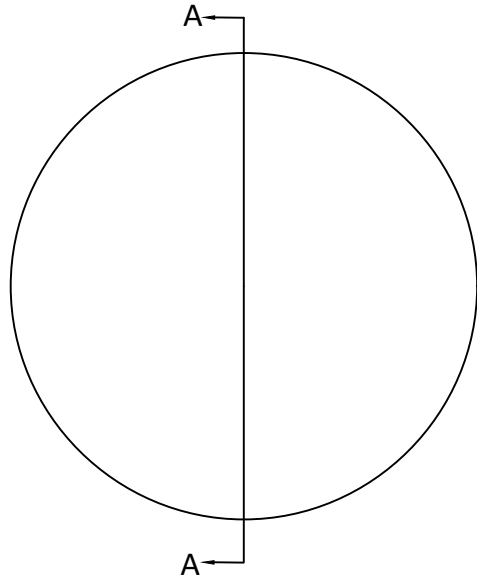

SECTION A-A

Notes:

1. ALL DIMENSIONS IN MM
2. TOLERANCE UNLESS SPECIFIED ± 0.10
3. MATERIAL: OPTICAL GLASS H-K9L
4. MANUFACTURE PER MIL-PRF-13830
5. POLISH TO TESTPLATE WITHIN POWER AND IRREGULARITY INDICATED (FRINGES)
6. FOCAL LENGTH(EFL): 125.00±1%
7. SURFACE QUALITY : 40-20 SCRATCH-DIG
8. CHAMFER EDGES: 0.5×45°MAX UNLESS SPECIFIED
9. CENTRATION TOLERANCE: 1.0' MINUTES MAX
10. COATING: S1 & S2: Ravg 0.8% @ 400-950nm @ 0° AOI

UNLESS OTHERWISE SPECIFIED:		NAME	DATE	
DIMENSIONS ARE IN mm		DRAWN	10.4.24	
TOLERANCES:		CHECK		TITLE: DIAMETER 38.10MM, EFL 125.00MM, H-K9L, VIS-NIR1 COTAED, PLANO-CONVEX LENS
FRACTIONAL ±		ENG APPR.		
ANGULAR: ±3 ARC MIN		MFG APPR.		
TWO PLACE DECIMAL: ±0.10		QA	12.18.24	
THREE PLACE DECIMAL: ±0.05		ANNOS		
INTERPRET GEOMETRIC TOLERANCING PER:		COMMENTS		
MATERIAL H-K9L				SIZE
FINISH				DWG.NO.
				REV
DO NOT SCALE DRAWING		PROJECT NO.		<b>A</b> <b>L-PX004012538Z</b> <b>0</b>
		SCALE:	WEIGHT:	SHEET 1 OF 1