

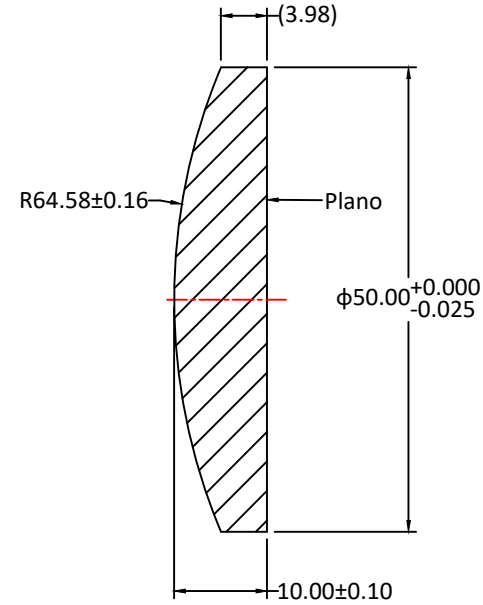

| RADIUS   | R TOL | POWER | IRRG | CA  | DIA   | DIA TOL   | MATERIAL | INDEX  | CT    | CT TOL |
|----------|-------|-------|------|-----|-------|-----------|----------|--------|-------|--------|
| 64.58 CX | ±0.16 | 3     | 0.5  | 90% | 50.00 | +0/-0.025 | H-K9L    | 517642 | 10.00 | ±0.10  |
| Plano    | -     | 3     | 0.5  | 90% |       |           |          |        |       |        |

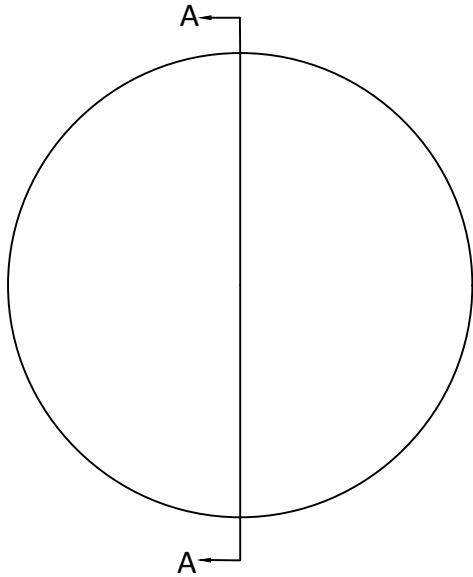

SECTION A-A

Notes:

1. ALL DIMENSIONS IN MM
2. TOLERANCE UNLESS SPECIFIED ± 0.10
3. MATERIAL: OPTICAL GLASS H-K9L
4. MANUFACTURE PER MIL-PRF-13830
5. POLISH TO TESTPLATE WITHIN POWER AND IRREGULARITY INDICATED (FRINGES)
6. FOCAL LENGTH(EFL): 125.00±1%
7. SURFACE QUALITY : 40-20 SCRATCH-DIG
8. CHAMFER EDGES: 0.5×45°MAX UNLESS SPECIFIED
9. CENTRATION TOLERANCE: 1.0' MINUTES MAX
10. COATING: S1 & S2: Ravg 0.8% @ 400-950nm @ 0° AOI

|                                      |  |                      |          |                                                                                        |
|--------------------------------------|--|----------------------|----------|----------------------------------------------------------------------------------------|
| UNLESS OTHERWISE SPECIFIED:          |  | NAME                 | DATE     |   |
| DIMENSIONS ARE IN mm                 |  | DRAWN                | 10.2.24  |                                                                                        |
| TOLERANCES:                          |  | CHECK                |          | TITLE:<br>DIAMETER 50.00MM, EFL 125.00MM, H-K9L, VIS-NIR1<br>COTAED, PLANO-CONVEX LENS |
| FRACTIONAL ±                         |  | ENG APPR.            |          |                                                                                        |
| ANGULAR: ±3 ARC MIN                  |  | MFG APPR.            |          |                                                                                        |
| TWO PLACE DECIMAL: ±0.10             |  | QA                   | 12.18.24 | SIZE DWG.NO. REV<br><b>A</b> L-PX0040125050 <b>0</b>                                   |
| THREE PLACE DECIMAL: ±0.05           |  | COMMENTS             |          |                                                                                        |
| INTERPRET GEOMETRIC TOLERANCING PER: |  | DO NOT SCALE DRAWING |          | PROJECT NO. SCALE: WEIGHT: SHEET 1 OF 1                                                |
| MATERIAL H-K9L                       |  |                      |          |                                                                                        |
| FINISH                               |  |                      |          |                                                                                        |