

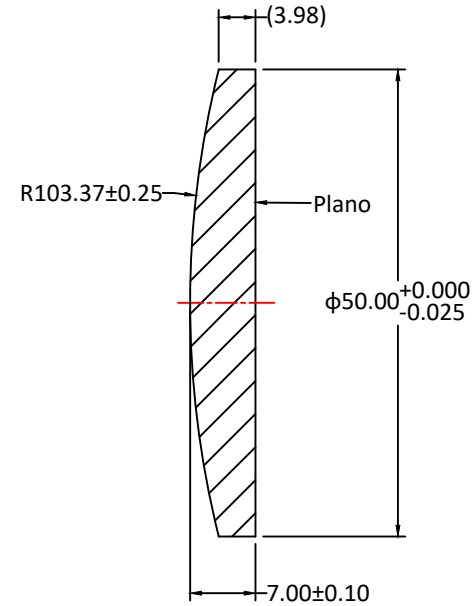

| RADIUS | R TOL | POWER | IRRG | CA | DIA | DIA TOL | MATERIAL | INDEX | CT | CT TOL |
|-----------|-------|-------|------|-----|-------|-----------|----------|--------|------|--------|
| 103.37 CX | ±0.25 | 3 | 0.5 | 90% | 50.00 | +0/-0.025 | H-K9L | 517642 | 7.00 | ±0.10 |
| Plano | - | 3 | 0.5 | 90% | | | | | | |

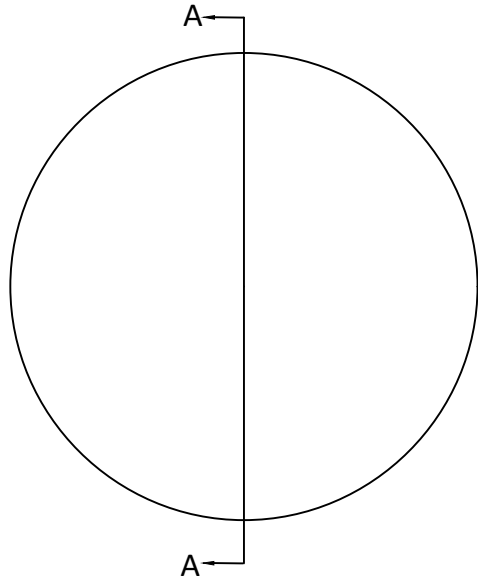

SECTION A-A

Notes:

1. ALL DIMENSIONS IN MM
2. TOLERANCE UNLESS SPECIFIED ± 0.10
3. MATERIAL: OPTICAL GLASS H-K9L
4. MANUFACTURE PER MIL-PRF-13830
5. POLISH TO TESTPLATE WITHIN POWER AND IRREGULARITY INDICATED (FRINGES)
6. FOCAL LENGTH(EFL): 200.00±1%
7. SURFACE QUALITY : 40-20 SCRATCH-DIG
8. CHAMFER EDGES: 0.5×45°MAX UNLESS SPECIFIED
9. CENTRATION TOLERANCE: 1.0' MINUTES MAX
10. COATING: S1 & S2: Ravg 0.8% @ 400-950nm @ 0° AOI

| | | | | |
|--|--|-----------|----------|--|
| UNLESS OTHERWISE SPECIFIED: | | NAME | DATE |  |
| DIMENSIONS ARE IN mm TOLERANCES: FRACTIONAL ± ANGULAR: ±3 ARC MIN TWO PLACE DECIMAL: ±0.10 THREE PLACE DECIMAL: ±0.05 | | DRAWN | 9.26.24 | |
| INTERPRET GEOMETRIC TOLERANCING PER: | | CHECK | | TITLE: DIAMETER 50.00MM, EFL 200.00MM, H-K9L, VIS-NIR1 COTAED, PLANO-CONVEX LENS |
| MATERIAL H-K9L | | ENG APPR. | | |
| FINISH | | MFG APPR. | | |
| DO NOT SCALE DRAWING | | QA | 12.18.24 | SIZE DWG.NO. A L-PX0040200050 |
| PROJECT NO. | | COMMENTS | | REV 0 |
| | | SCALE: | WEIGHT: | SHEET 1 OF 1 |