

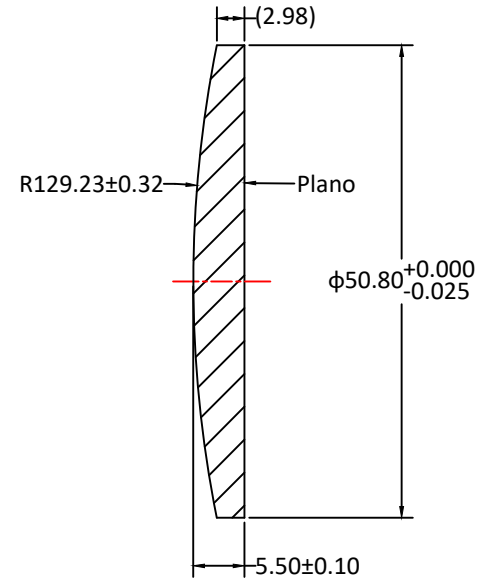

RADIUS	R TOL	POWER	IRRG	CA	DIA	DIA TOL	MATERIAL	INDEX	CT	CT TOL
129.23 CX	±0.32	3	0.5	90%	50.80	+0/-0.025	H-K9L	517642	5.50	±0.10
Plano	-	3	0.5	90%						

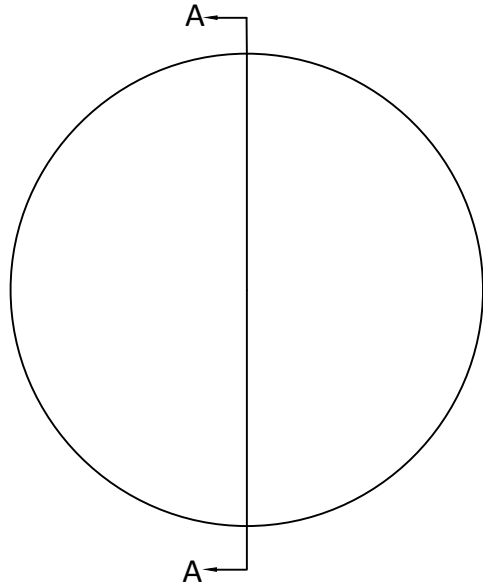

SECTION A-A

Notes:

1. ALL DIMENSIONS IN MM
2. TOLERANCE UNLESS SPECIFIED ± 0.10
3. MATERIAL: OPTICAL GLASS H-K9L
4. MANUFACTURE PER MIL-PRF-13830
5. POLISH TO TESTPLATE WITHIN POWER AND IRREGULARITY INDICATED (FRINGES)
6. FOCAL LENGTH(EFL): 250.00±1%
7. SURFACE QUALITY : 40-20 SCRATCH-DIG
8. CHAMFER EDGES: 0.5×45°MAX UNLESS SPECIFIED
9. CENTRATION TOLERANCE: 1.0' MINUTES MAX
10. COATING: S1 & S2: Ravg 0.8% @ 400-950nm @ 0° AOI

UNLESS OTHERWISE SPECIFIED:		NAME	DATE		
DIMENSIONS ARE IN mm		Sally Song	9.15.24		
TOLERANCES:		CHECK		TITLE: DIAMETER 50.80MM, EFL 250.00MM, H-K9L, VIS-NIR1 COTAED, PLANO-CONVEX LENS	
FRACTIONAL ±		ENG APPR.			
ANGULAR: ±3 ARC MIN		MFG APPR.			
TWO PLACE DECIMAL: ±0.10		QA	Ann Chen 12.18.24	SIZE DWG.NO. REV A L-PX004025050Z 0	
THREE PLACE DECIMAL: ±0.05		COMMENTS			
INTERPRET GEOMETRIC TOLERANCING PER:				SCALE:	
MATERIAL H-K9L				WEIGHT:	
FINISH				SHEET 1 OF 1	
DO NOT SCALE DRAWING		PROJECT NO.			