

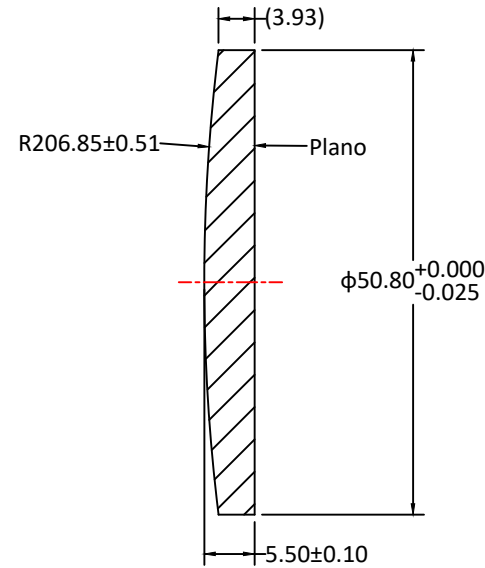

RADIUS	R TOL	POWER	IRRG	CA	DIA	DIA TOL	MATERIAL	INDEX	CT	CT TOL
206.85 CX	±0.51	3	0.5	90%	50.80	+0/-0.025	H-K9L	517642	5.50	±0.10
Plano	-	3	0.5	90%						

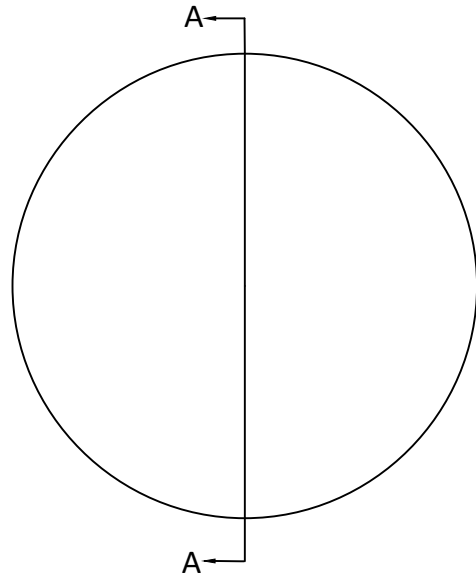

SECTION A-A

Notes:

1. ALL DIMENSIONS IN MM
2. TOLERANCE UNLESS SPECIFIED ± 0.10
3. MATERIAL: OPTICAL GLASS H-K9L
4. MANUFACTURE PER MIL-PRF-13830
5. POLISH TO TESTPLATE WITHIN POWER AND IRREGULARITY INDICATED (FRINGES)
6. FOCAL LENGTH(EFL): 400.00±1%
7. SURFACE QUALITY : 40-20 SCRATCH-DIG
8. CHAMFER EDGES: 0.5×45°MAX UNLESS SPECIFIED
9. CENTRATION TOLERANCE: 1.0' MINUTES MAX
10. COATING: S1 & S2: Ravg 0.8% @ 400-950nm @ 0° AOI

UNLESS OTHERWISE SPECIFIED:		NAME	DATE		
DIMENSIONS ARE IN mm TOLERANCES: FRACTIONAL ± ANGULAR: ±3 ARC MIN TWO PLACE DECIMAL: ±0.10 THREE PLACE DECIMAL: ±0.05		DRAWN	Sally Song		
INTERPRET GEOMETRIC TOLERANCING PER:		CHECK			
MATERIAL H-K9L		ENG APPR.			
FINISH		MFG APPR.			
DO NOT SCALE DRAWING		QA	Ann Chen	12.18.24	SIZE A DWG.NO. L-PX004040050Z REV 0
PROJECT NO.		SCALE:		WEIGHT:	SHEET 1 OF 1