

RADIUS	R TOL	POWER	IRRG	CA	DIA	DIA TOL	MATERIAL	INDEX	CT	CT TOL
103.37 CX	±0.25	3	0.5	90%	40.00	+0/-0.025	H-K9L	517642	5.00	±0.10
Plano	-	3	0.5	90%						

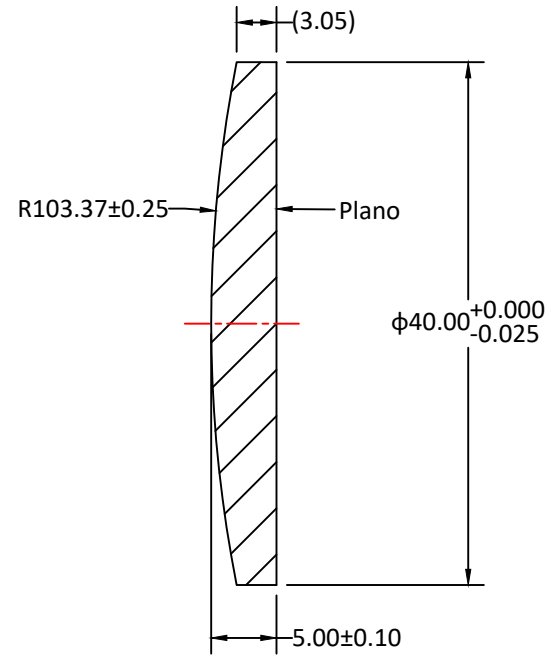
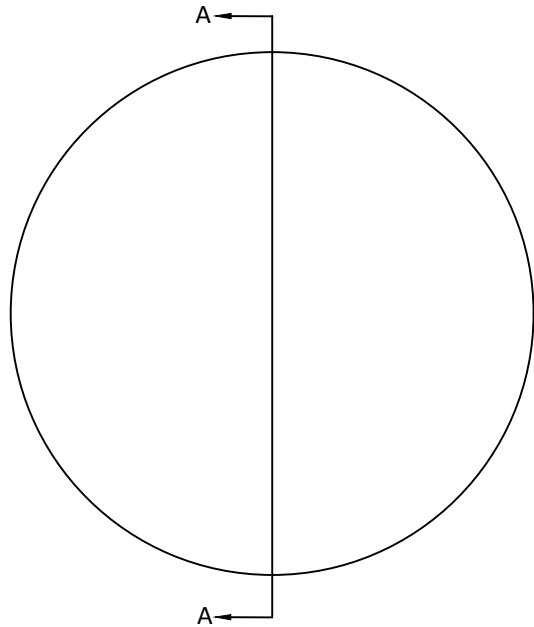

SECTION A-A

Notes:

1. ALL DIMENSIONS IN MM
2. TOLERANCE UNLESS SPECIFIED ± 0.10
3. MATERIAL: OPTICAL GLASS H-K9L
4. MANUFACTURE PER MIL-PRF-13830
5. POLISH TO TESTPLATE WITHIN POWER AND IRREGULARITY INDICATED (FRINGES)
6. FOCAL LENGTH(EFL): $200.00 \pm 1\%$
7. SURFACE QUALITY : 40-20 SCRATCH-DIG
8. CHAMFER EDGES: $0.5 \times 45^\circ$ MAX UNLESS SPECIFIED
9. CENTRATION TOLERANCE: 1.0' MINUTES MAX
10. COATING: S1 & S2: $R_{avg} 0.5\% @ 630-1100nm @ 0^\circ AOI$

UNLESS OTHERWISE SPECIFIED:	NAME	DATE				
DIMENSIONS ARE IN mm	DRAWN	Sally Song				9.14.24
TOLERANCES:	CHECK			TITLE: DIAMETER 40.00MM, EFL 200.00MM, H-K9L,NIR 1 COATED, PLANO-CONVEX LENS		
FRACTIONAL \pm	ENG APPR.					
ANGULAR: ± 3 ARC MIN	MFG APPR.					
TWO PLACE DECIMAL: ± 0.10	QA	Ann Chen	12.18.24			
THREE PLACE DECIMAL: ± 0.05	COMMENTS			SIZE	DWG.NO.	REV
INTERPRET GEOMETRIC TOLERANCING PER:				A	L-PX0050200040	0
MATERIAL H-K9L				SCALE:	WEIGHT:	SHEET 1 OF 1
FINISH						
DO NOT SCALE DRAWING	PROJECT NO.					