

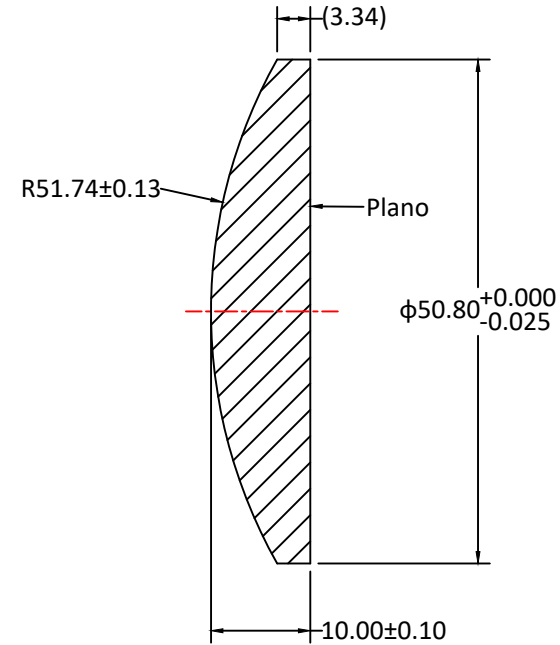

RADIUS	R TOL	POWER	IRRG	CA	DIA	DIA TOL	MATERIAL	INDEX	CT	CT TOL
51.74 CX	±0.13	3	0.5	90%	50.80	+0/-0.025	H-K9L	517642	10.00	±0.10
Plano	-	3	0.5	90%						

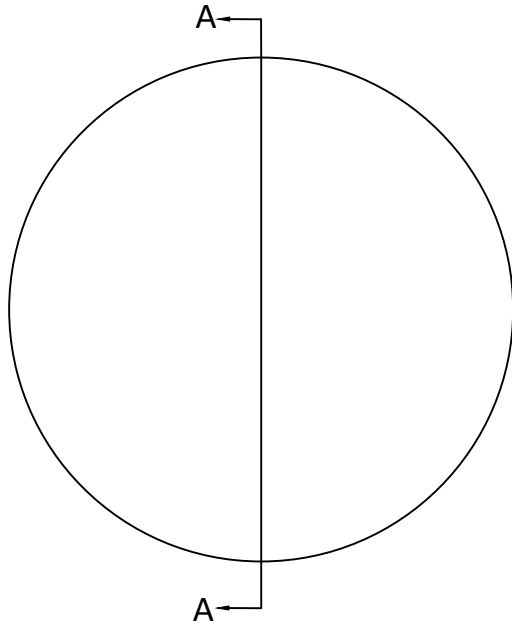

SECTION A-A

Notes:

1. ALL DIMENSIONS IN MM
2. TOLERANCE UNLESS SPECIFIED ± 0.10
3. MATERIAL: OPTICAL GLASS H-K9L
4. MANUFACTURE PER MIL-PRF-13830
5. POLISH TO TESTPLATE WITHIN POWER AND IRREGULARITY INDICATED (FRINGES)
6. FOCAL LENGTH(EFL): 100.00±1%
7. SURFACE QUALITY : 40-20 SCRATCH-DIG
8. CHAMFER EDGES: 0.5×45°MAX UNLESS SPECIFIED
9. CENTRATION TOLERANCE: 1.0' MINUTES MAX
10. COATING: S1 & S2: Ravg<0.5% @1050-1700nm @ 0°AOI

UNLESS OTHERWISE SPECIFIED:		NAME	DATE	 <p>TITLE: DIAMETER 50.80MM, EFL 100.00MM, H-K9L, NIR 2 COATED, PLANO-CONVEX LENS</p>		
DIMENSIONS ARE IN mm TOLERANCES: FRACTIONAL ± ANGULAR: ±3 ARC MIN TWO PLACE DECIMAL: ±0.10 THREE PLACE DECIMAL: ±0.05	DRAWN	Eva Du	9.28.24			
	CHECK	Royan Luo	10.2.24			
	ENG APPR.					
	MFG APPR.					
INTERPRET GEOMETRIC TOLERANCING PER:	QA	Ann Chen	12.18.24			
MATERIAL H-K9L	COMMENTS			SIZE		
FINISH				DWG.NO.		
DO NOT SCALE DRAWING	PROJECT NO.			A	L-PX006010050Z	REV
		SCALE:	WEIGHT:			0
				SHEET 1 OF 1		