

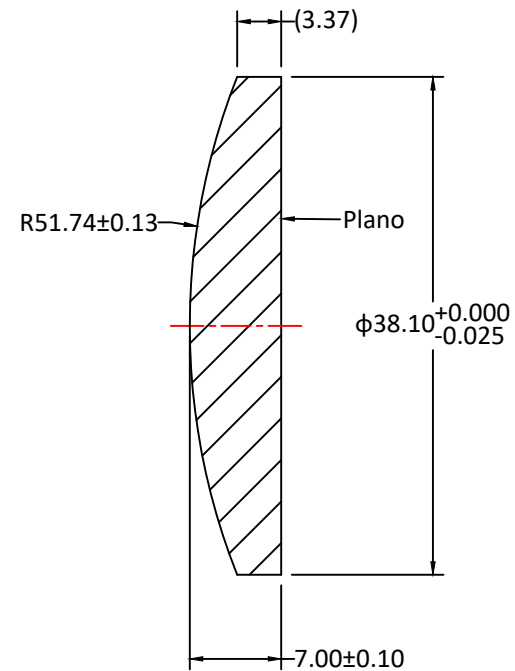

RADIUS	R TOL	POWER	IRRG	CA	DIA	DIA TOL	MATERIAL	INDEX	CT	CT TOL
51.74 CX	±0.13	3	0.5	90%	38.10	+0/-0.025	H-K9L	517642	7.00	±0.10
Plano	-	3	0.5	90%						

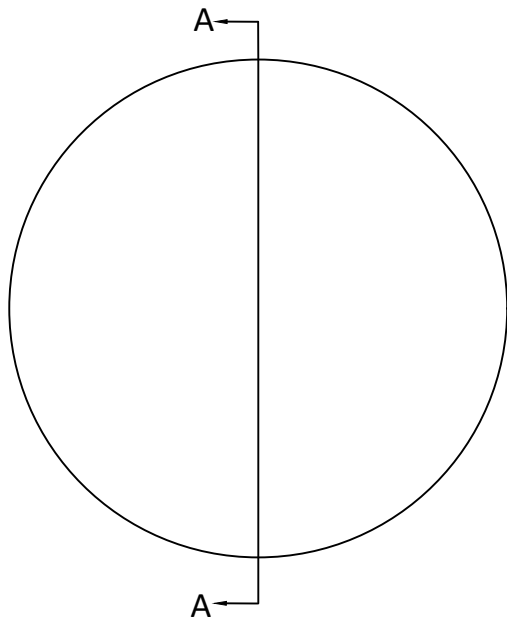

SECTION A-A

Notes:

1. ALL DIMENSIONS IN MM
2. TOLERANCE UNLESS SPECIFIED ± 0.10
3. MATERIAL: OPTICAL GLASS H-K9L
4. MANUFACTURE PER MIL-PRF-13830
5. POLISH TO TESTPLATE WITHIN POWER AND IRREGULARITY INDICATED (FRINGES)
6. FOCAL LENGTH(EFL): $100.00 \pm 1\%$
7. SURFACE QUALITY : 40-20 SCRATCH-DIG
8. CHAMFER EDGES: $0.5 \times 45^\circ$ MAX UNLESS SPECIFIED
9. CENTRATION TOLERANCE: 1.0' MINUTES MAX
10. COATING: S1 & S2: $\frac{1}{4}$ WAVE MgF2 @ 550nm R(AVG) < 1.75% FROM 400-700nm H-K9L

UNLESS OTHERWISE SPECIFIED:		NAME	DATE			
DIMENSIONS ARE IN mm		DRAWN	Sally Song			10.8.24
TOLERANCES:		CHECK			TITLE: DIAMETER 38.10MM, EFL 100.00MM, H-K9L, MgF2 COATED, PLANO-CONVEX LENS	
FRACTIONAL \pm		ENG APPR.				
ANGULAR: ± 3 ARC MIN		MFG APPR.				
TWO PLACE DECIMAL: ± 0.10		QA	Ann Chen	12.18.24		
THREE PLACE DECIMAL: ± 0.05		COMMENTS				
INTERPRET GEOMETRIC TOLERANCING PER:				SIZE	DWG.NO.	REV
MATERIAL H-K9L				A	L-PX002010038Z	0
FINISH						
DO NOT SCALE DRAWING		PROJECT NO.		SCALE:	WEIGHT:	SHEET 1 OF 1