

| RADIUS | R TOL | POWER | IRRG | CA | DIA | DIA TOL | MATERIAL | INDEX | CT | CT TOL |
|----------|-------|-------|------|-----|-------|-----------|----------|--------|------|--------|
| 64.58 CX | ±0.16 | 3 | 0.5 | 90% | 35.00 | +0/-0.025 | H-K9L | 517642 | 7.00 | ±0.10 |
| Plano | - | 3 | 0.5 | 90% | | | | | | |

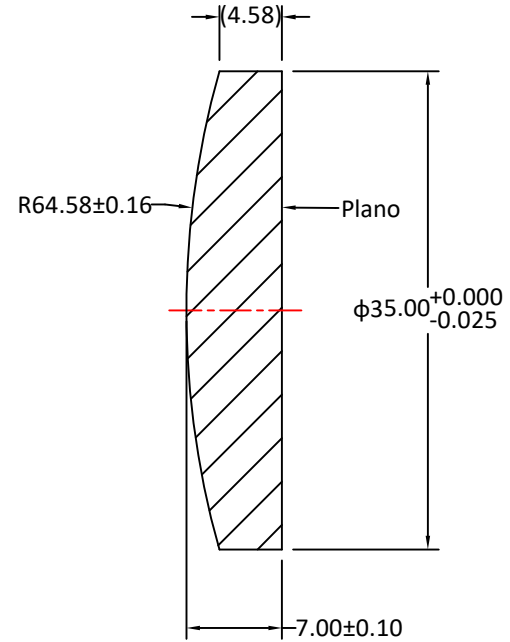
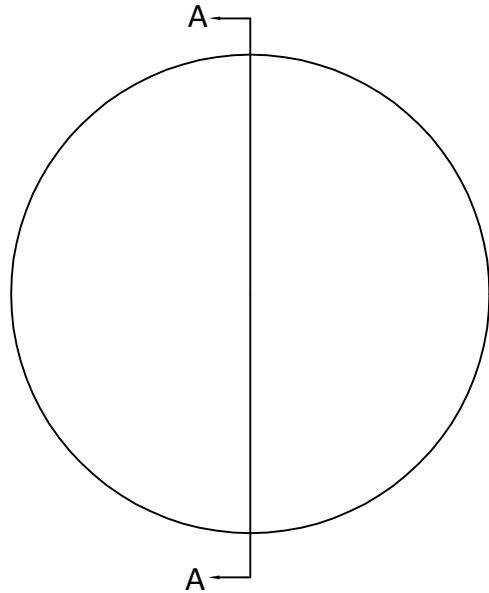

SECTION A-A

Notes:

- ALL DIMENSIONS IN MM
- TOLERANCE UNLESS SPECIFIED ± 0.10
- MATERIAL: OPTICAL GLASS H-K9L
- MANUFACTURE PER MIL-PRF-13830
- POLISH TO TESTPLATE WITHIN POWER AND IRREGULARITY INDICATED (FRINGES)
- FOCAL LENGTH(EFL): 125.00±1%
- SURFACE QUALITY : 40-20 SCRATCH-DIG
- CHAMFER EDGES: 0.5×45°MAX UNLESS SPECIFIED
- CENTRATION TOLERANCE: 1.0' MINUTES MAX
- COATING: UNCOATED

| | | | | |
|--|--|-----------|----------------|---|
| UNLESS OTHERWISE SPECIFIED: | | NAME | DATE | |
| DIMENSIONS ARE IN mm TOLERANCES: FRACTIONAL ± ANGULAR: ±3 ARC MIN TWO PLACE DECIMAL: ±0.10 THREE PLACE DECIMAL: ±0.05 | | DRAWN | Sally Song | |
| INTERPRET GEOMETRIC TOLERANCING PER: | | CHECK | | |
| MATERIAL H-K9L | | ENG APPR. | | |
| FINISH | | MFG APPR. | | |
| DO NOT SCALE DRAWING | | QA | | |
| PROJECT NO. | | COMMENTS | | TITLE: DIAMETER 35.00MM, EFL 125.00MM, H-K9L PLANO CONVEX LENSES |
| SCALE: | | SIZE | DWG.NO. | REV |
| WEIGHT: | | A | L-PX0010125035 | 0 |
| SHEET 1 OF 1 | | | | |