

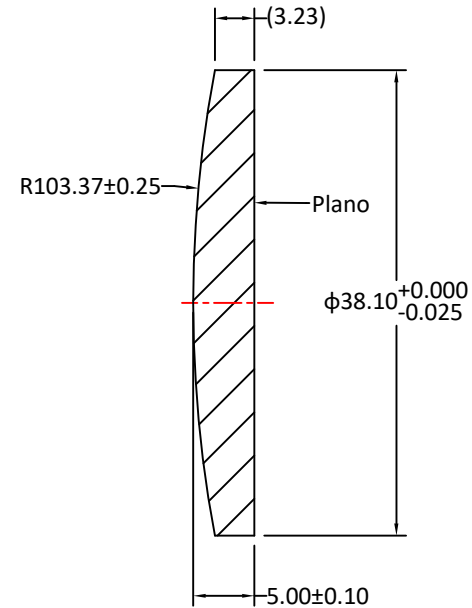

RADIUS	R TOL	POWER	IRRG	CA	DIA	DIA TOL	MATERIAL	INDEX	CT	CT TOL
103.37 CX	±0.25	3	0.5	90%	38.10	+0/-0.025	H-K9L	517642	5.00	±0.10
Plano	-	3	0.5	90%						

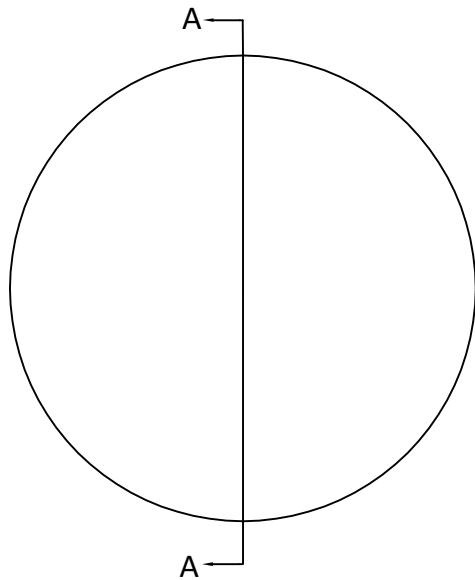

SECTION A-A

Notes:

1. ALL DIMENSIONS IN MM
2. TOLERANCE UNLESS SPECIFIED ± 0.10
3. MATERIAL: OPTICAL GLASS H-K9L
4. MANUFACTURE PER MIL-PRF-13830
5. POLISH TO TESTPLATE WITHIN POWER AND IRREGULARITY INDICATED (FRINGES)
6. FOCAL LENGTH(EFL): 200.00±1%
7. SURFACE QUALITY : 40-20 SCRATCH-DIG
8. CHAMFER EDGES: 0.5×45°MAX UNLESS SPECIFIED
9. CENTRATION TOLERANCE: 1.0' MINUTES MAX
10. COATING: UNCOATED

UNLESS OTHERWISE SPECIFIED:		NAME	DATE	
DIMENSIONS ARE IN mm		DRAWN	9.28.24	
TOLERANCES:		CHECK		TITLE: DIAMETER 38.10MM, EFL 200.00MM, H-K9L PLANO CONVEX LENSES
FRACTIONAL ±		ENG APPR.		
ANGULAR: ±3 ARC MIN		MFG APPR.		
TWO PLACE DECIMAL: ±0.10		QA		SIZE DWG.NO. REV A L-PX001020038Z 0
THREE PLACE DECIMAL: ±0.05		COMMENTS		
INTERPRET GEOMETRIC TOLERANCING PER:				SCALE: WEIGHT: SHEET 1 OF 1
MATERIAL H-K9L				
FINISH				
DO NOT SCALE DRAWING	PROJECT NO.			