

RADIUS	R TOL	POWER	IRRG	CA	DIA	DIA TOL	MATERIAL	INDEX	CT	CT TOL
129.23 CX	±0.32	3	0.5	90%	35.00	+0/-0.025	H-K9L	517642	5.00	±0.10
Plano	-	3	0.5	90%						

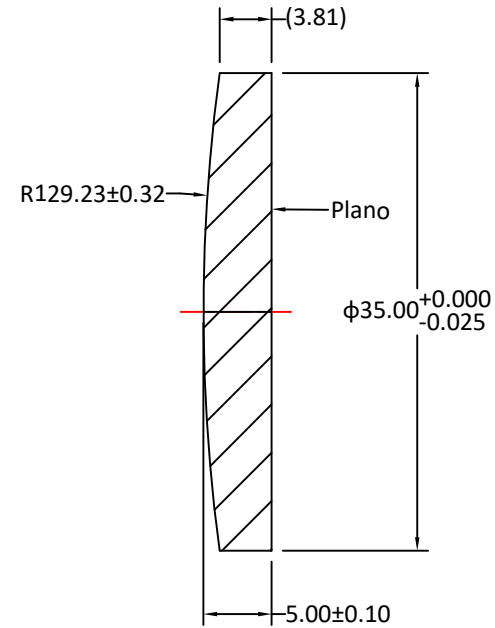
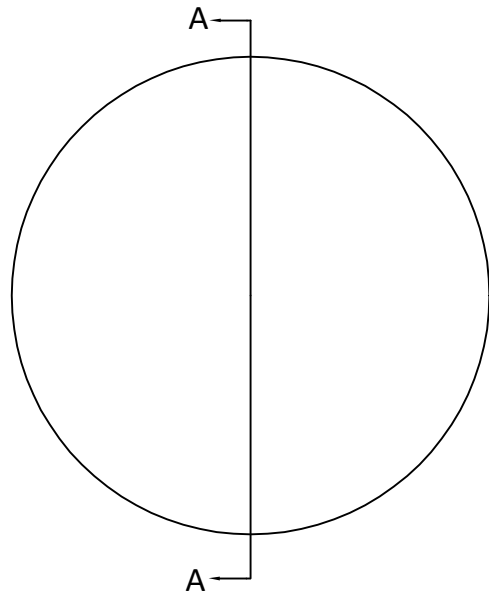

SECTION A-A

Notes:

1. ALL DIMENSIONS IN MM
2. TOLERANCE UNLESS SPECIFIED ± 0.10
3. MATERIAL: OPTICAL GLASS H-K9L
4. MANUFACTURE PER MIL-PRF-13830
5. POLISH TO TESTPLATE WITHIN POWER AND IRREGULARITY INDICATED (FRINGES)
6. FOCAL LENGTH(EFL): 250.00±1%
7. SURFACE QUALITY : 40-20 SCRATCH-DIG
8. CHAMFER EDGES: 0.5×45°MAX UNLESS SPECIFIED
9. CENTRATION TOLERANCE: 1.0' MINUTES MAX
10. COATING: UNCOATED

UNLESS OTHERWISE SPECIFIED:		NAME	DATE	
DIMENSIONS ARE IN mm TOLERANCES: FRACTIONAL ± ANGULAR: ±3 ARC MIN TWO PLACE DECIMAL: ±0.10 THREE PLACE DECIMAL: ±0.05		DRAWN Sally Song	9.12.24	
INTERPRET GEOMETRIC TOLERANCING PER:		CHECK		TITLE: DIAMETER 35.00MM, EFL 250.00MM, H-K9L PLANO CONVEX LENSES
MATERIAL H-K9L		ENG APPR.		
FINISH		MFG APPR.		
DO NOT SCALE DRAWING		QA		SIZE DWG.NO. <b>A</b> L-PX0010250035
PROJECT NO.		COMMENTS		
SCALE:		WEIGHT:	SHEET 1 OF 1	REV <b>0</b>