

RADIUS	R TOL	POWER	IRRG	CA	DIA	DIA TOL	MATERIAL	INDEX	CT	CT TOL
206.85 CX	±0.51	3	0.5	90%	35.00	+0/-0.025	H-K9L	517642	5.00	±0.10
Plano	-	3	0.5	90%						

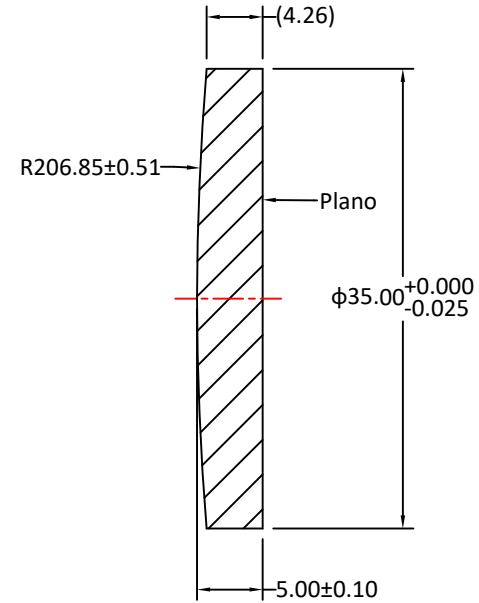
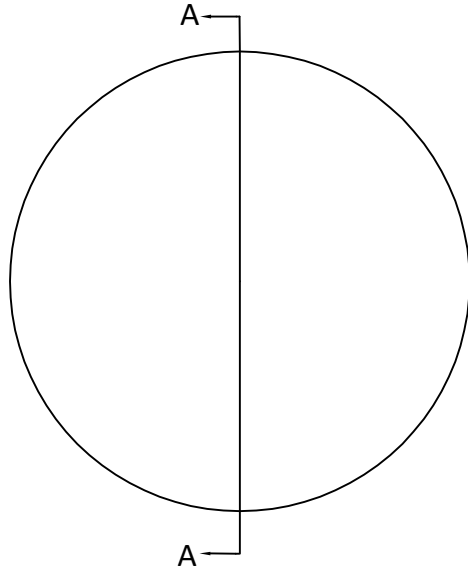

SECTION A-A

Notes:

1. ALL DIMENSIONS IN MM
2. TOLERANCE UNLESS SPECIFIED  $\pm 0.10$
3. MATERIAL: OPTICAL GLASS H-K9L
4. MANUFACTURE PER MIL-PRF-13830
5. POLISH TO TESTPLATE WITHIN POWER AND IRREGULARITY INDICATED (FRINGES)
6. FOCAL LENGTH(EFL):  $400.00 \pm 1\%$
7. SURFACE QUALITY : 40-20 SCRATCH-DIG
8. CHAMFER EDGES:  $0.5 \times 45^\circ$  MAX UNLESS SPECIFIED
9. CENTRATION TOLERANCE: 1.0' MINUTES MAX
10. COATING: UNCOATED

UNLESS OTHERWISE SPECIFIED:		NAME	DATE				
DIMENSIONS ARE IN mm		DRAWN	Sally Song			9.10.24	
TOLERANCES:		CHECK			TITLE: DIAMETER 35.00MM, EFL 400.00MM, H-K9L PLANO CONVEX LENSES		
FRACTIONAL $\pm$		ENG APPR.					
ANGULAR: $\pm 3$ ARC MIN		MFG APPR.					
TWO PLACE DECIMAL: $\pm 0.10$		QA					
THREE PLACE DECIMAL: $\pm 0.05$		COMMENTS			SIZE	DWG.NO.	REV
INTERPRET GEOMETRIC TOLERANCING PER:					<b>A</b>	L-PX0010400035	<b>0</b>
MATERIAL H-K9L							
FINISH							
DO NOT SCALE DRAWING		PROJECT NO.			SCALE:	WEIGHT:	SHEET 1 OF 1