

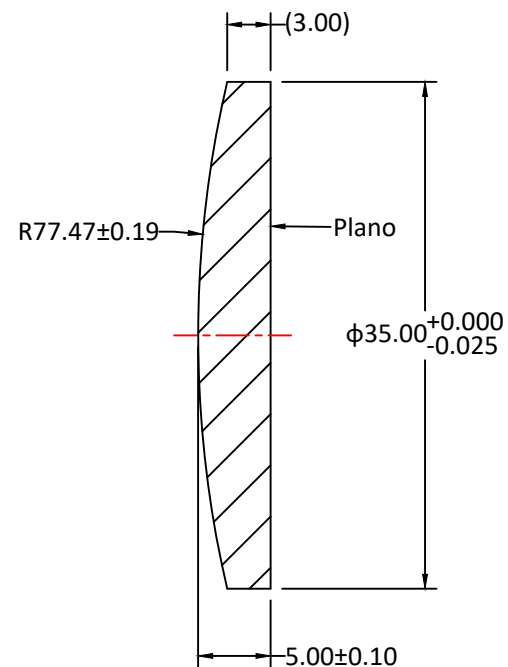

RADIUS	R TOL	POWER	IRRG	CA	DIA	DIA TOL	MATERIAL	INDEX	CT	CT TOL
77.47 CX	±0.19	3	0.5	90%	35.00	+0/-0.025	H-K9L	517642	5.00	±0.10
Plano	-	3	0.5	90%						

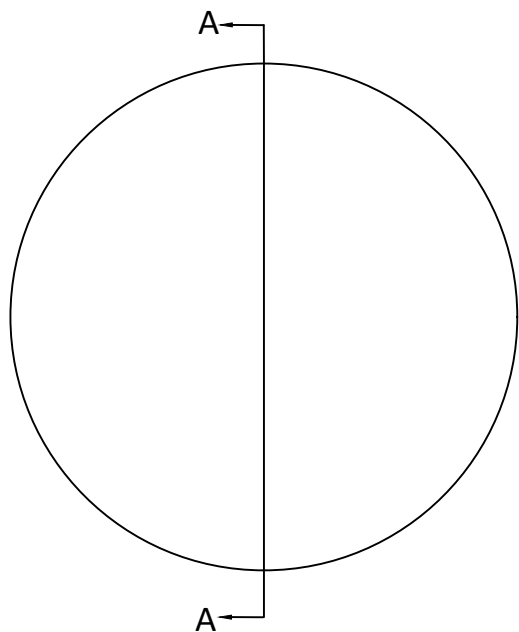

SECTION A-A

Notes:

1. ALL DIMENSIONS IN MM
2. TOLERANCE UNLESS SPECIFIED ± 0.10
3. MATERIAL: OPTICAL GLASS H-K9L
4. MANUFACTURE PER MIL-PRF-13830
5. POLISH TO TESTPLATE WITHIN POWER AND IRREGULARITY INDICATED (FRINGES)
6. FOCAL LENGTH(EFL): 150.00±1%
7. SURFACE QUALITY : 40-20 SCRATCH-DIG
8. CHAMFER EDGES: 0.5×45°MAX UNLESS SPECIFIED
9. CENTRATION TOLERANCE: 1.0' MINUTES MAX
10. COATING: S1 & S2: ¼ WAVE MgF2 @ 550nm R(AVG) < 1.75% FROM 400-700nm H-K9L

UNLESS OTHERWISE SPECIFIED:		NAME	DATE		
DIMENSIONS ARE IN mm		DRAWN	10.8.24		
TOLERANCES:		CHECK		TITLE: DIAMETER 35.00MM, EFL 150.00MM, H-K9L, MgF2 COATED, PLANO-CONVEX LENS	
FRACTIONAL ±		ENG APPR.			
ANGULAR: ±3 ARC MIN		MFG APPR.			
TWO PLACE DECIMAL: ±0.10		QA	12.18.24	SIZE DWG.NO. REV A L-PX0020150035 0	
THREE PLACE DECIMAL: ±0.05		COMMENTS			
INTERPRET GEOMETRIC TOLERANCING PER:					
MATERIAL H-K9L					
FINISH					
DO NOT SCALE DRAWING		PROJECT NO.		SCALE:	WEIGHT:
				SHEET 1 OF 1	