

RADIUS	R TOL	POWER	IRRG	CA	DIA	DIA TOL	MATERIAL	INDEX	CT	CT TOL
206.85 CX	±0.51	3	0.5	90%	35.00	+0/-0.025	H-K9L	517642	5.00	±0.10
Plano	-	3	0.5	90%						

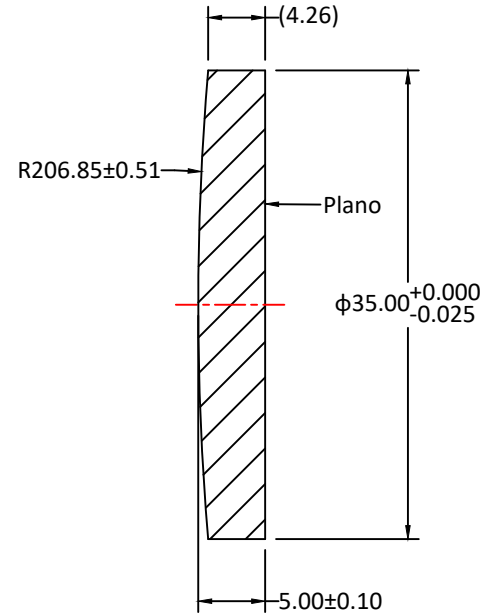
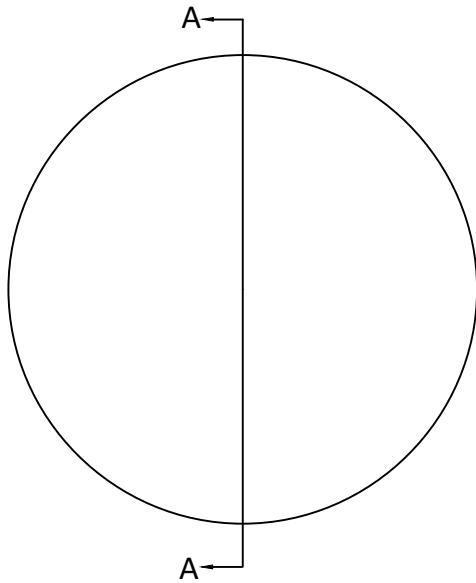

SECTION A-A

Notes:

1. ALL DIMENSIONS IN MM
2. TOLERANCE UNLESS SPECIFIED ± 0.10
3. MATERIAL: OPTICAL GLASS H-K9L
4. MANUFACTURE PER MIL-PRF-13830
5. POLISH TO TESTPLATE WITHIN POWER AND IRREGULARITY INDICATED (FRINGES)
6. FOCAL LENGTH(EFL): 400.00±1%
7. SURFACE QUALITY : 40-20 SCRATCH-DIG
8. CHAMFER EDGES: 0.5×45°MAX UNLESS SPECIFIED
9. CENTRATION TOLERANCE: 1.0' MINUTES MAX
10. COATING: S1 & S2: Ravg<0.35% @ 420-680nm @ 0° AOI

UNLESS OTHERWISE SPECIFIED:		NAME	DATE				
DIMENSIONS ARE IN mm		DRAWN	Sally Song			9.10.24	
TOLERANCES:		CHECK			TITLE: DIAMETER 35.00MM, EFL 400.00MM, H-K9L, VIS 0 COATED, PLANO-CONVEX LENS		
FRACTIONAL ±		ENG APPR.					
ANGULAR: ±3 ARC MIN		MFG APPR.					
TWO PLACE DECIMAL: ±0.10		QA	Ann Chen	12.18.24			
THREE PLACE DECIMAL: ±0.05		COMMENTS			SIZE	DWG.NO.	REV
INTERPRET GEOMETRIC TOLERANCING PER:				A L-PX0030400035		0	
MATERIAL H-K9L				SCALE:	WEIGHT:	SHEET 1 OF 1	
FINISH							
DO NOT SCALE DRAWING		PROJECT NO.					