

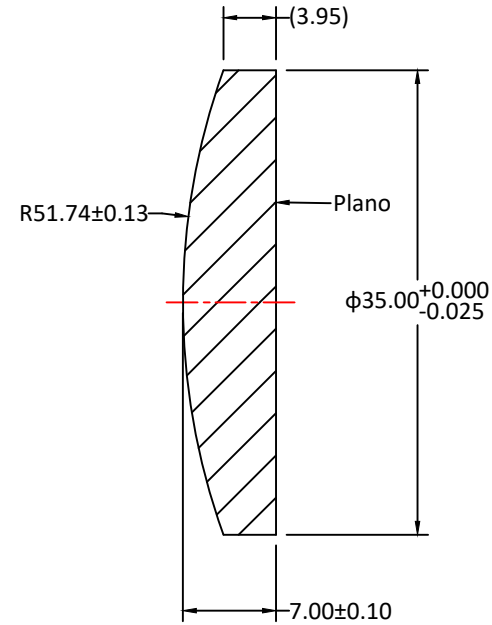

RADIUS	R TOL	POWER	IRRG	CA	DIA	DIA TOL	MATERIAL	INDEX	CT	CT TOL
51.74 CX	±0.13	3	0.5	90%	35.00	+0/-0.025	H-K9L	517642	7.00	±0.10
Plano	-	3	0.5	90%						

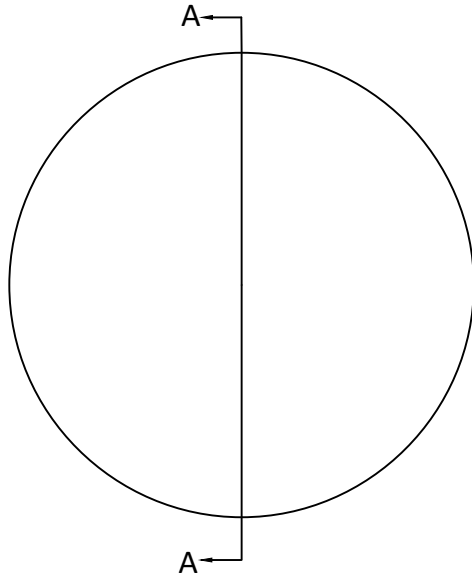

SECTION A-A

Notes:

1. ALL DIMENSIONS IN MM
2. TOLERANCE UNLESS SPECIFIED ± 0.10
3. MATERIAL: OPTICAL GLASS H-K9L
4. MANUFACTURE PER MIL-PRF-13830
5. POLISH TO TESTPLATE WITHIN POWER AND IRREGULARITY INDICATED (FRINGES)
6. FOCAL LENGTH(EFL): 100.00±1%
7. SURFACE QUALITY : 40-20 SCRATCH-DIG
8. CHAMFER EDGES: 0.5×45°MAX UNLESS SPECIFIED
9. CENTRATION TOLERANCE: 1.0' MINUTES MAX
10. COATING: S1 & S2: Ravg 0.8% @ 400-950nm @ 0° AOI

UNLESS OTHERWISE SPECIFIED:		NAME	DATE	
DIMENSIONS ARE IN mm TOLERANCES: FRACTIONAL ± ANGULAR: ±3 ARC MIN TWO PLACE DECIMAL: ±0.10 THREE PLACE DECIMAL: ±0.05	DRAWN	Eva Du	10.8.24	
	CHECK	Sally Song	10.12.24	
	ENG APPR.			
INTERPRET GEOMETRIC TOLERANCING PER:	MFG APPR.			TITLE: DIAMETER 35.00MM, EFL 100.00MM, H-K9L, VIS-NIR1 COTAED, PLANO-CONVEX LENS
MATERIAL H-K9L	QA	Ann Chen	12.18.24	SIZE DWG.NO. REV
FINISH	COMMENTS			<b>A</b> L-PX0040100035 <b>0</b>
DO NOT SCALE DRAWING	PROJECT NO.	SCALE:	WEIGHT:	SHEET 1 OF 1