

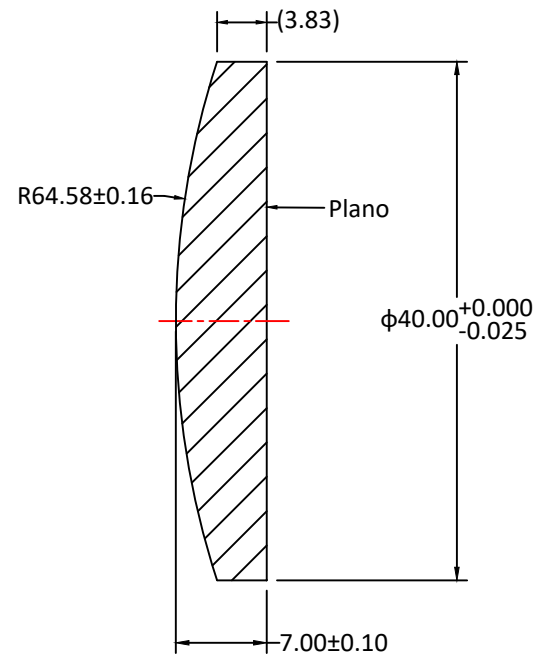

RADIUS	R TOL	POWER	IRRG	CA	DIA	DIA TOL	MATERIAL	INDEX	CT	CT TOL
64.58 CX	±0.16	3	0.5	90%	40.00	+0/-0.025	H-K9L	517642	7.00	±0.10
Plano	-	3	0.5	90%						

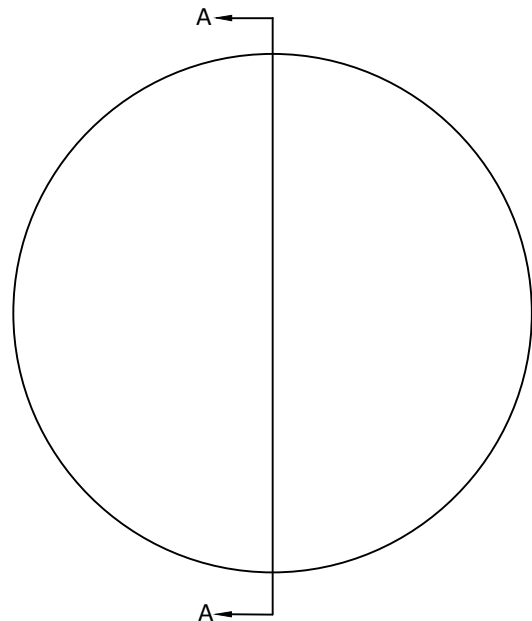

SECTION A-A

Notes:

1. ALL DIMENSIONS IN MM
2. TOLERANCE UNLESS SPECIFIED ± 0.10
3. MATERIAL: OPTICAL GLASS H-K9L
4. MANUFACTURE PER MIL-PRF-13830
5. POLISH TO TESTPLATE WITHIN POWER AND IRREGULARITY INDICATED (FRINGES)
6. FOCAL LENGTH(EFL): 125.00±1%
7. SURFACE QUALITY : 40-20 SCRATCH-DIG
8. CHAMFER EDGES: 0.5×45°MAX UNLESS SPECIFIED
9. CENTRATION TOLERANCE: 1.0' MINUTES MAX
10. COATING: S1 & S2: ¼ WAVE MgF2 @ 550nm R(AVG) < 1.75% FROM 400-700nm H-K9L

UNLESS OTHERWISE SPECIFIED:		NAME	DATE				
DIMENSIONS ARE IN mm		DRAWN	Sally Song			9.14.24	
TOLERANCES:		CHECK			<b>TITLE:</b> DIAMETER 40.00MM, EFL 125.00MM, H-K9L, MgF2 COATED, PLANO-CONVEX LENS		
FRACTIONAL ±		ENG APPR.					
ANGULAR: ±3 ARC MIN		MFG APPR.					
TWO PLACE DECIMAL: ±0.10		QA	Ann Chen	12.18.24	<b>SIZE</b> <b>DWG.NO.</b> <b>A</b> <b>L-PX0020125040</b>		
THREE PLACE DECIMAL: ±0.05		COMMENTS		<b>REV</b> <b>0</b>			
INTERPRET GEOMETRIC TOLERANCING PER:		DO NOT SCALE DRAWING			PROJECT NO.	SCALE:	WEIGHT:
MATERIAL H-K9L							
FINISH							