

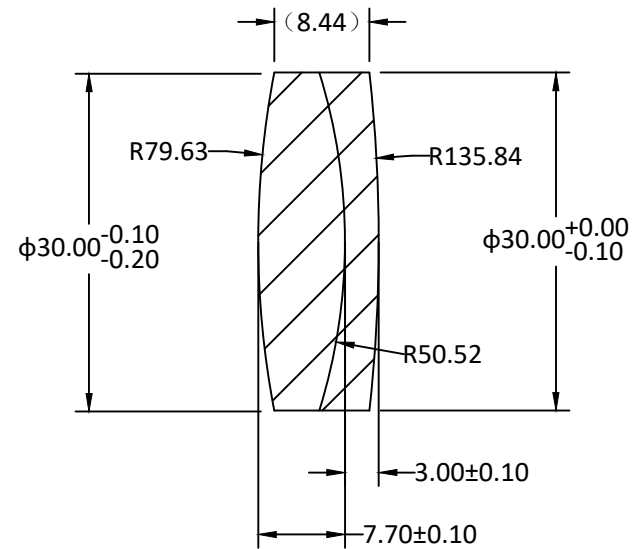

| RADIUS | R TOL | POWER | IRRG | CA | DIA | DIA TOL | MATERIAL | INDEX | CT | CT TOL |
|-----------|-------|-------|------|-----|-------|-------------|----------|---------|------|--------|
| 79.63 CX | ±0.16 | 3 | 1 | 90% | 30.00 | -0.10/-0.20 | N-BK7 | 517-642 | 7.70 | ±0.10 |
| 50.52 | ±0.10 | 3 | 1 | 90% | 30.00 | +0/-0.10 | N-SF5 | 673-322 | 3.00 | ±0.10 |
| 135.84 CX | ±0.27 | 3 | 1 | 90% | | | | | | |

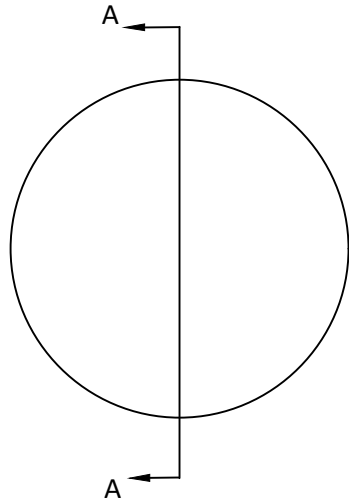

SECTION A-A

Notes:

1. ALL DIMENSIONS IN MM
2. TOLERANCE UNLESS SPECIFIED ± 0.10
3. MATERIAL GRADE B, FA PER MIL-G-174, SCHOTT OR EQUIVALENT, RoHS COMPLIANT
4. MANUFACTURE PER MIL-PRF-13830
5. POLISH TO TESTPLATE WITHIN POWER AND IRREGULARITY INDICATED (FRINGES)
6. SURFACE QUALITY : 60-40 SCRATCH-DIG
7. CHAMFER EDGES: $0.5 \times 45^\circ$ MAX UNLESS SPECIFIED
8. CENTRATION TOLERANCE: 3.0' MINUTES MAX
9. EFL: $120\text{MM} \pm 2\%$
10. DESIGN WAVELENGTH: 587.6NM
11. COATING: UNCOATED
12. CEMENT USUNG NORLAND NOA61 OR EQUIVALENT

| | | | | | |
|--------------------------------------|--|--------------|------------|---|---|
| UNLESS OTHERWISE SPECIFIED: | | NAME | DATE |  | |
| DIMENSIONS ARE IN mm | | DRAWN | Sally Song | | |
| TOLERANCES: | | CHECK | | | TITLE: DIAMETER 30MM, EFL 120MM, ACHROMAT LENS |
| FRACTIONAL \pm | | ENG APPR. | | | |
| ANGULAR: ± 3 ARC MIN | | MFG APPR. | | | |
| TWO PLACE DECIMAL: ± 0.10 | | QA | Ann Chen | 12.18.24 | |
| THREE PLACE DECIMAL: ± 0.05 | | COMMENTS | | | SIZE |
| INTERPRET GEOMETRIC TOLERANCING PER: | | | | | DWG.NO. |
| MATERIAL | | | | | A |
| FINISH | | | | | L-AC0010120030 |
| DO NOT SCALE DRAWING | | PROJECT NO. | | | REV |
| | | SCALE: 1:1 | | | WEIGHT: |
| | | SHEET 1 OF 1 | | | 0 |