

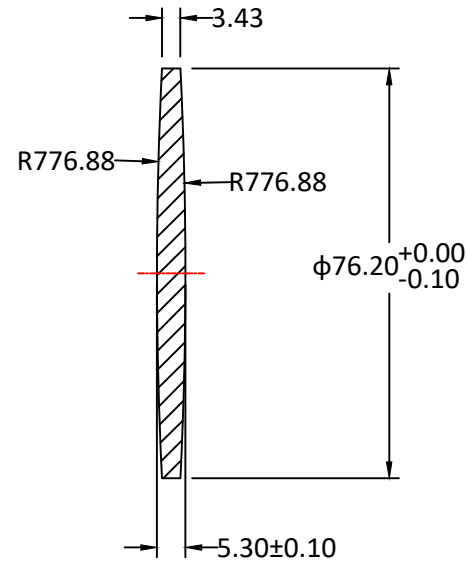

RADIUS	R TOL	POWER	IRRG	CA	DIA	DIA TOL	MATERIAL	INDEX	CT	CT TOL
776.88 CX	±1.55	3	1	90%	76.20	+0/-0.10	H-K9L	517642	5.30	±0.10
-776.88 CX	±1.55	3	1	90%						

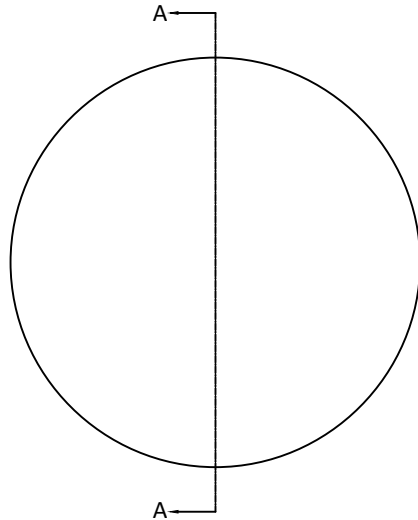

SECTION A-A

Notes:

1. ALL DIMENSIONS IN MM
2. TOLERANCE UNLESS SPECIFIED ± 0.10
3. MATERIAL: GRADE B, FA PER MIL-G-174, CDGM OR EQUIVALENT, ROHS COMPLIANT
4. MANUFACTURE PER MIL-PRF-13830
5. POLISH TO TESTPLATE WITHIN POWER AND IRREGULARITY INDICATED (FRINGES)
6. FOCAL LENGTH(EFL): 750mm±2%
7. SURFACE QUALITY : 60-40 SCRATCH-DIG
8. CHAMFER EDGES: 0.5×45°MAX UNLESS SPECIFIED
9. CENTRATION TOLERANCE:3.0' MINUTES MAX
10. COATING:NONE

UNLESS OTHERWISE SPECIFIED:		NAME	DATE	
DIMENSIONS ARE IN mm		DRAWN	Sally Song 03.26.25	
TOLERANCES:		CHECK		TITLE: DIAMETER 76.20MM, EFL 750MM, H-K9L BICONVEX LENS
FRACTIONAL ±		ENG APPR.		
ANGULAR: ±3 ARC MIN		MFG APPR.		
TWO PLACE DECIMAL: ±0.10		QA	Ann Chen 01.18.25	SIZE DWG.NO. REV A L-DX001075076Z 0
THREE PLACE DECIMAL: ±0.05		COMMENTS		
INTERPRET GEOMETRIC TOLERANCING PER:				SCALE:
MATERIAL H-K9L				WEIGHT:
FINISH				SHEET 1 OF 1
DO NOT SCALE DRAWING		PROJECT NO.		